

HEWLETT-PACKARD JOURNAL

JANUARY 1985

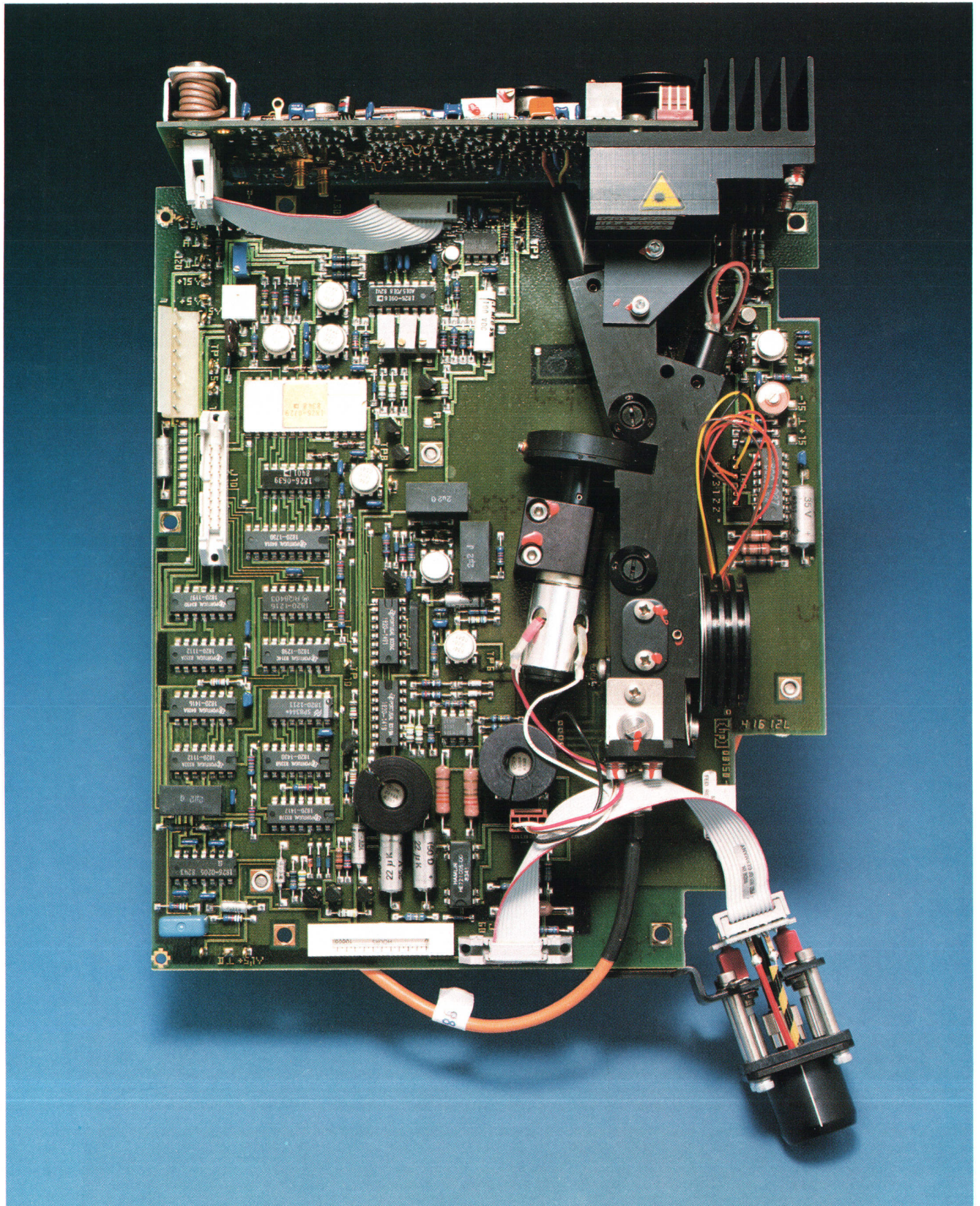

HEWLETT-PACKARD JOURNAL

January 1985 Volume 36 • Number 1

Articles

4 **Optical Stimulus and Receivers for Parametric Testing in Fiber Optics**, by *Achim Eckert and Wolfgang Schmid* Now you don't have to build your own system for fiber optic testing. These new instruments cover a wide range of applications.

6 **Handling Fiber Optic Components**

7 **A Precise, Programmable 850-nm Optical Signal Source**, by *Wolfgang Schmid, Bernhard Flade, Klaus Hoeing, and Rainer Eggert* Modulate the output using the internal pulse/function generator or your own external source.

8 **Laser Safety Practices**

18 **A Versatile, Programmable Optical Pulse Power Meter**, by *Werner Berkel, Hans Huning, Volker Eberle, Josef Becker, Bernd Maisenbacher, Wilfried Pless, and Michael Goder* There's a choice of optical heads for operation at 550 to 950 nm or 950 to 1750 nm.

27 **An Optical Receiver for 550 to 950 nm**, by *Michael Fleischer-Reumann, Emmerich Müller, and Gerd Koffmane* Convert your oscilloscope or voltmeter to a fiber optic instrument with this optical-to-electrical transducer.

29 **Optical Standards**, by *Werner Berkel and Joachim Vobis* Precise secondary standards had to be built to test a new line of instruments.

31 **Authors**

In this Issue

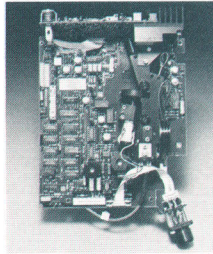

Fiber optic communications links are finding their way into a growing number of applications, from local computer networks to long-distance telephone lines. In these areas and many others, such as data acquisition, process control, building automation, traffic control, cable television, and airborne systems, fiber optic cables are doing jobs once exclusively done by metallic conductors such as coaxial cables or twisted pairs. Depending on the application, the advantages of communicating with light guided by glass fibers instead of electricity guided by wires include immunity from electromagnetic interference, no electromagnetic emissions, freedom from ground loops, smaller cable size, lighter cable weight, greater bandwidth to carry more channels, longer link length without repeaters, and in some cases, lower cost.

The use of fiber optic cables, transmitters, and receivers, which have been available for many years from Hewlett-Packard and other manufacturers, has outdistanced the availability of versatile, precise fiber optic test instrumentation. However, the new HP products described by their designers in this issue go a long way towards closing this gap. The HP 8150A Optical Signal Source (page 7) contains an infrared laser diode, circuits to ensure that the diode's light output is precisely controlled, and facilities for modulating the light output by either internally or externally generated electrical signals. This instrument can produce a variety of calibrated optical signals for testing optical receivers, cables, and connectors. The HP 8151A Optical Pulse Power Meter (page 18) measures the light output of optical transmitters, cables, and connectors. In this instrument and its companion optical head are an optical-to-electrical transducer and circuits to measure not only the average light power, but also the high and low peaks and their ratio. A third instrument, the HP 81519A Optical Receiver (page 27), contains only an optical-to-electrical transducer; it's for users who want to convert their conventional electronic test instruments for fiber optic work. On our cover this month is the miniature optical bench from the HP 8150A. See page 14 for a detailed look at this precision assembly.

These new HP fiber optic instruments are designed for testing relatively short-distance links using multimode fiber optic technology and either step-index or graded-index fibers. For long-haul telecommunications links, characterized by distances greater than 20 kilometers and data rates greater than 200 megabytes per second, monomode technology is used and another kind of instrumentation is required.

-R.P. Dolan

What's Ahead

Scheduled for the February issue are an article about a new software package for HP 9000 Series 200 Computers and a pair of research reports. The software package, HP TechWriter, lets Series 200 users edit text and merge it with graphics to produce illustrated documents. One of the research reports describes the investigation that led to the introduction of disc caching on HP 3000 Computers. The other report describes the application of magnetostatic waves in thin ferrimagnetic films to a variety of electronic devices for processing microwave signals.

Optical Stimulus and Receivers for Parametric Testing in Fiber Optics

An optical power source and an optical pulse power meter, both calibrated and programmable, provide reliable device and system testing for the expanding field of fiber optics.

by Achim Eckert and Wolfgang Schmid

OFFERING SIGNIFICANT ADVANTAGES over conventional techniques, such as coaxial or twisted-pair cables, fiber optic systems are gaining momentum in a large variety of applications. Typical environments, aside from telecommunications, are computer and local area networks, data acquisition, process control, building automation, traffic control, CATV, and airborne systems. The design and production of such systems, their modules, and the components that go into them require test equipment capable of more than just a functional checkout. Comprehensive design verification is needed, ranging from the precise determination of bandwidth, flatness, or pulse response to the measurement of thresholds, sensitivity, and linearity.

Such tasks can be performed only with fiber optic test equipment that has parametric capabilities. With the HP 8150A Optical Signal Source and the HP 8151A Optical Pulse Power Meter, Fig. 1, HP is offering a new family of instruments with these parametric characteristics, as well as high precision and capabilities not previously commercially available. Hence, thorough testing of fiber optic components, modules, and systems can be performed at high confidence levels.

These new instruments offer peak power measurement (HP 8151A) and direct setting of calibrated optical levels via front-panel keys (HP 8150A). Both instruments incorporate large-bandwidth transducers, which provide easy conversion from electrical to optical signals (HP 8150A) and

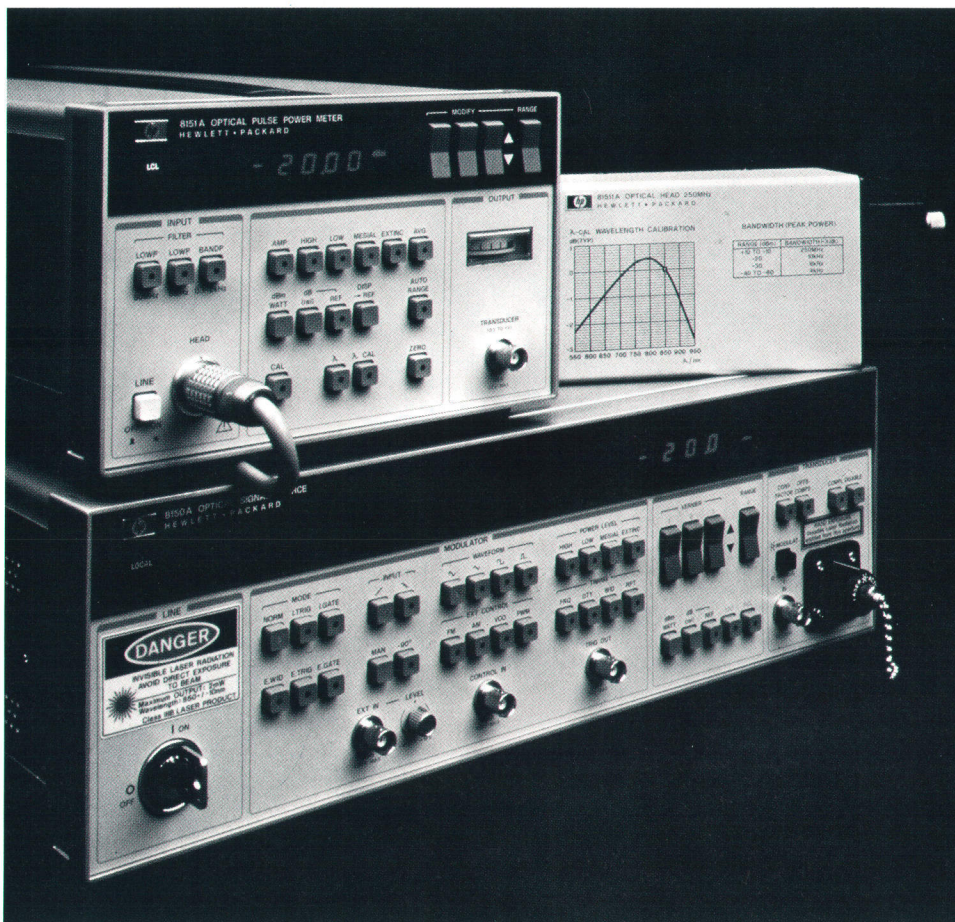

Fig. 1. Two new products, the HP 8150A Optical Signal Source (bottom) and the HP 8151A Optical Pulse Power Meter (top left, shown with the HP 8151A Optical Head), are precise, fully programmable stimulus and response-measuring instruments for design and production testing of fiber optic devices and systems at short wavelengths.

from optical to electrical signals (HP 8151A) up to 250 MHz.

These instruments are designed as fundamental engineering tools for fiber optics labs, incoming inspection, manufacturing test, and quality assurance. They are expected to be highly useful instruments for contractors and suppliers of fiber optic components and modules and fiber optic systems in computer or local area networks, industrial electronics, and telecommunications for short-distance networks.

Optical Signal Sources

Like their electronics counterparts, fiber optics design and production test engineers use sources, in this case optical sources, to stimulate components or systems for verification of their performance. In many cases the optical source consists of a self-built device based on an LED or a laser diode. Even if the source is a commercially available instrument, its output light level is usually not precisely known because the user must rely on the characteristic curve of the LED or the laser, with all its inaccuracies and temperature dependence, to determine the output power. This means that measurements where known levels are essential cannot be performed reliably. One example is the determination of the threshold levels of optical receivers.

Testing receiver sensitivity or stimulating larger optical systems demands optical stimuli that offer a wide power range. In such situations engineers normally have to use an optical attenuator to adjust light levels to the desired value because the typical dynamic range of available sources is around 20 dB, insufficient to provide all of the levels needed. However, with an external attenuator, the actual output optical signal is not well-defined. Hence, time-consuming reference measurements are necessary.

For design verification of optical devices and links, optical signals must be applied that correspond in speed, shape, and levels to the signals encountered under actual operating conditions. This problem is frequently solved by modulating the optical source with an electrical signal. Again, self-built setups often do not control the source well enough to prevent the modulation from affecting the source itself. Modulation noise and temperature fluctuation are typical examples of such effects.

Finally, the interfacing to the device under test still seems to be a critical issue. Because of the lack of standardization in fiber optic connectors and test procedures, there is usually no clear-cut definition of what the connector actually does to the optical signal, except for loss. Yet, for any precise and repeatable measurement the user must have a comprehensive description or specification of the optical signal when it enters the device under test.

The new HP 8150A Optical Signal Source provides an answer to these problems. Its main element is an electrical-to-optical transducer, which can be modulated with analog or digital signals from dc to 250 MHz. This large bandwidth, coupled with variable transducer gain, covers the major requirements in terms of speed and power range for testing networks, industrial links, and short-distance communication systems.

Major features of the HP 8150A include well-defined optical output levels, precision programmable attenuators, internal modulation for simulating real-life signals, and

well-specified interfacing to the device under test. The HP 8150A is described in detail in the article on page 7.

Optical Power Meters

Undoubtedly one of the most important and commonly performed fiber optic tests is the measurement of optical power. The transmission of energy from one point in a system to another requires verification of power levels during design, manufacturing, and operation. Such tests determine the magnitude of power emitted from light sources (laser or LED) and power lost in connectors, splices, and fiber inhomogeneities.

Existing power meters typically measure the average value of optical signals, using pin photodiodes or other receiving elements. Knowledge of only average power can be meaningless, however, in situations where the signal consists of a digital data stream. Since the average power is a function of the duty cycle, the average power will vary according to the mark-space ratio of the optical input. This effect is even greater, of course, when the data stream includes long pauses, as is often the case during data transmission.

Another typical situation is the measurement of signals that consist of a constant light level (dc) modulated by an ac component subject to bandwidth limitation. Again, average power measurements lead to inaccurate results, because they cannot measure the reduction of the ac component when the bandwidth limit of an optical transmitter, for instance, is reached.

Available power meters also lack the ability to provide direct access to the optical signal being measured. Complex and expensive splitting methods are usually necessary to make the electrical equivalent of the optical input available for viewing on an oscilloscope, for example, or for further processing with any other electronic test instrument.

The new HP 8151A Optical Pulse Power Meter, in combination with the HP 81511A or HP 81512A Optical Head, offers solutions to these measurement problems. It makes both peak and average power measurements with $\pm 2.5\%$ accuracy. It provides transducer capability, making the electrical equivalent of the optical modulation available for other uses. It interfaces easily to a variety of fiber optic connectors. The HP 8151A and the HP 81511A are described in the article on page 18.

Optical Receiver

A third new HP fiber optics instrument, the HP 81519A Optical Receiver, is a 400-MHz optical-to-electrical transducer for those who want to use their electronic test instruments for fiber optics work. This instrument is discussed on page 27.

Design and Development Issues

In the process of developing a completely new breed of fiber optics measurement instruments within a traditionally electronics-oriented HP division, we had to deal with a large set of new problems, besides the normal questions and problems of any new development:

- Evaluation of new components, many of which were still under development (e.g., laser diodes, glass fibers, and connectors)

Handling Fiber Optic Components

Although HP's new fiber optic measurement tools are designed to operate like their electrical equivalents with the single difference of having a glass fiber input or output instead of an electrical connection, it is important to be aware of what this difference really means.

Rigidity of Fiber Optic Cables

The heart of the cable is a glass fiber with a diameter of 125 μm . The light-carrying core is even smaller, namely 50 μm . This fiber is surrounded by a number of coatings to protect the fiber and to enhance its stability. Although the pulling force can be rather high (about 50N, or 250N short-term) one must be careful in bending the cable. The minimum bending radius should not be less than 50 mm. Even if bending doesn't harm the cable, the attenuation may increase significantly.

Mode Coupling

The type of cable HP uses is called multimode because the light is transmitted through a large number (around 500) of different zigzag rays, called modes, within the fiber core (Fig. 1). The light is transported because total internal reflection (TIR) occurs at the core/cladding boundary within a certain range of angles.

Bending the cable changes this angle of incidence locally with the effect that TIR vanishes. Higher modes are no longer reflected back into the core, but penetrate into the surrounding cladding where they are eventually absorbed (Fig. 2). In some types of cables, these cladding modes are maintained for some distance (several meters or more).

In any case, these cladding modes mean additional and normally unintentional losses. The losses are greater if the light distribution within the cable is out of equilibrium. In the HP 8150A Optical Power Source, therefore, care has been taken to establish the desired equilibrium mode distribution (EMD) at the instrument's output. Nevertheless, for precision measurements within tenths of a dB, it is important not to move the cables during the measurement.

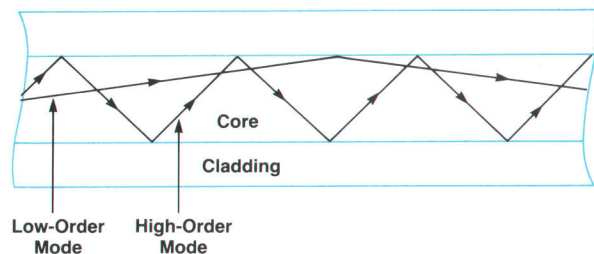

Fig. 1. Mode propagation in a step-index glass fiber. Typically, modes number around 500 for graded-index profiles and around 1000 for step-index profiles.

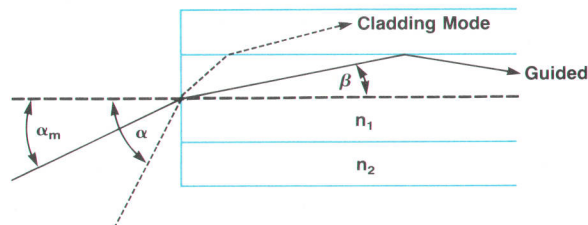

Fig. 2. Only modes with angles smaller than α_m or β are guided. Larger angles cause penetration into the cladding, where absorption eventually occurs.

Connectors

The variety of fiber optics connectors offered today is huge and no standardization is in sight. There is also a considerable gap between specifications and reality in normal environments. Since a precision measurement instrument requires a precision fiber optics connector, the HP 8150A's built-in connector is machined to very close specifications ($<1 \mu\text{m}$) and is of the preadjusted type. This means the fiber core is actively adjusted to the center of each connector individually, thus cancelling a number of fiber tolerances.

This high connector precision is only useful if the equipment is properly handled. Any contamination of the fiber end at the connector face by dust particles, fingerprints, or incorrect cleaning methods must be avoided, since these effects can easily yield an additional connector attenuation of 1 dB, thus deteriorating the accuracy of the instrument. For this reason, each instrument is furnished with a special cleaning kit.

Connectors with Matching Fluids

The normal fiber-to-fiber coupling is a butt transition with a tiny air gap in between (dry coupling). Besides yielding 8% reflection within the connector (4% Fresnel loss at each glass-to-air transition), which is a fixed value and is taken into account in the specifications, there may be multiple interferences between the fiber surfaces.

Since the laser light is coherent and the air gap is on the order of light wavelengths, any slight change of this air gap might alter the interference pattern and change the attenuation of the connector transition. This effect is common to all butt-coupled connectors and is in the order of 0.1 dB. In the HP connector, the end faces have a slight angle, so that these interferences are greatly reduced. However, for the utmost measurement stability, these interferences can be avoided completely by inserting a matching fluid between the fiber ends. This immersion oil is also provided with the cleaning kit.

Wolfgang Schmid

Project Leader

Böblingen Instruments Division

- Design of optics for miniature components with dimensions in the μm region
- Construction of precise, rigid mechanics to hold the optical components needed for imaging, splitting, and attenuating the light beam, while at the same time allowing for slight adjustments
- Developing processes to hold the different optical components (gluing, centering, and laser welding)
- Construction of optomechanical tools to adjust the optical parts precisely and actively

- Design of precision electrooptical standards to verify the specifications of the instruments accurately over wide dynamic and frequency ranges
- Construction of various safety circuits to eliminate any possible danger to the user and to meet international safety requirements.

Design Goals

Our design goals for the new instruments were:

- Design instruments that are as universal as possible to

overcome uncertainties about how to measure the parameters of interest.

- Design instruments that set standards and enable the user to do measurements easily and quickly, with a minimum of additional instruments.
- Design the instruments so that one can perform fiber optic measurements in the same way as electrical measurements, since familiarity greatly reduces errors,

simplifies measurements, and broadens the range of applications.

- Make the operation as easy and as foolproof as possible. Foresee potential problems and try to give practical solutions, even if the problems are not very obvious right now.
- Other articles in this issue describe how various issues were addressed and the design goals met.

A Precise, Programmable 850-nm Optical Signal Source

by Wolfgang Schmid, Bernhard Flade, Klaus Hoeing, and Rainer Eggert

THE HP 8150A OPTICAL SIGNAL SOURCE (Fig. 1) is a general-purpose stimulus source for various kinds of fiber optic measurements. It produces optical power over a range of 1 nW to 2 mW, a dynamic range of 63 dB. Hence one can measure from the sensitivity limits of optical receivers at very low light powers up to their saturation limits at high powers. This optical power output can be modulated by electrical signals in a broad frequency range of dc to 250 MHz, allowing real-time measurements of fast components. Other performance highlights include:

- High accuracy and stability. ± 0.5 dB relative and ± 1 dB absolute accuracy gives reliable power levels without the need of checking the level before each measurement. Stability of ± 0.05 dB enables repetitive measurements of even small changes, for example, in splice losses.
- Low signal distortion means that not only can digital

performance be measured, but also analog parameters such as linearity and signal degradation. Total harmonic distortion of the HP 8150A is less than 2%.

- Convenient power setting. With just a few keystrokes, one can control the light parameters easily and quickly, in the terminology of the application.
- User-friendly specifications. The optical output specifications apply to the light power *within* the fiber pigtail, including connector losses. This means that the output is specified where it is used.
- Cleanable fiber optic connectors. Contamination of any fiber optic connector by dust, fingerprints, or other substances deteriorates the performance and can make precision measurements impossible. The HP 8150A output connector is easily cleaned, and a cleaning kit is furnished with the instrument.

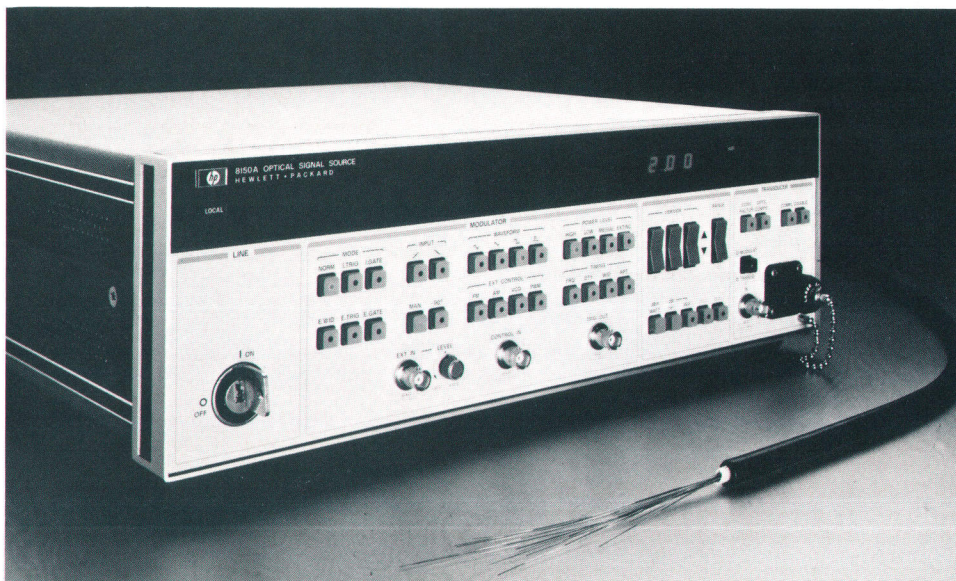

Fig. 1. The HP 8150A Optical Signal Source produces optical power at a wavelength of 850 nm over a range of 1 nW to 2 mW. Power level accuracy is ± 0.5 dB relative and ± 1 dB absolute, stability is ± 0.05 dB, and total harmonic distortion is less than 2%. Internal or external modulation of the optical signal is possible over a frequency range of dc to 250 MHz.

Laser Safety Practices

Lasers emit radiant energy, which may cause eye damage if certain values are exceeded. These values depend on the wavelength, with the maximum permissible exposure increasing with wavelength. Since energy is important, these values also change with the exposure time, the worst case being continuous exposure (CW), which is achievable with the HP 8150A Optical Signal Source. International standards are set by IEC Publication 76(CO)6; its recommendations have been widely adopted.

From the values given in this publication and for typical radiation patterns, a critical viewing distance can be derived. For the output of the HP 8150A, which is via a graded-index fiber, there is a critical distance of 70 mm (2.77 in) for the worst case of 2 mW CW. Several other publications suggest a minimum distance at which the eye can focus on an object. This distance is considered to be about 60 mm. Comparing these two values indicates that the HP 8150A can almost be considered safe. However, we recommend not looking into open fiber ends at all if the fiber is illuminated. If this is necessary, wear protective eyeglasses, which can be ordered separately from HP (HP Part Number 9300-1094).

Safety Regulations

All laser products have to be classified to establish suitable means to protect the user from dangerous light power levels.

The IEC distinguishes five classes (1, 2, 3A, 3B, 4), with class 1 being inherently safe and class 4 considered to be dangerous.

For each class there are certain safety requirements. In the case of the HP 8150A, which falls into class 3B, the following are required:

- Safety information in the local language
- Protective housing
- Warning and aperture labels
- Key control for the ac line switch
- Audible or visible **LASER ON** sign
- Automatic beamstop
- Remote control.

The HP 8150A meets these requirements. It has also passed a safety test performed by the German Laser Committee of the Berufsgenossenschaft and is allowed to carry the GS (geprüfte Sicherheit) label, which is comparable with the VDE label.

- Adapters for different connectors. There is a large variety of fiber optic connectors on the market, many of them not precise enough to be incorporated into the HP 8150A. Our approach is to use a precision connector (Diamond HFS1) at the instrument's output. The user has the choice of either connecting the external circuit to the bare end of the 2-meter pigtail supplied or using adapter cables, which we also offer, and which include some of the most widely used connector types. The instrument's output is specified at the end of the 2-m pigtail.
- Extensive self-test capabilities give confidence in the instrument's performance and ensure immediate information about the instrument's status.
- HP-IB (IEEE 488) capabilities. The HP 8150A can be incorporated into a measuring system under computer control, for example, in production testing or quality assurance.

Technical Contributions

Some special approaches and techniques had to be im-

plemented to achieve the HP 8150A's specifications, performance, and features.

To achieve the high output power of 2 mW together with the high bandwidth of 250 MHz, we use a laser diode, which in turn means extensive stabilization and control circuitry. The huge dynamic range of 63 dB in light output power led to development of a special optical system, a miniature optical bench with passive attenuators. The low distortion demanded a wideband control loop, which senses the actual front-facet light of the laser diode (a departure from the more common method, back-facet monitoring) and uses only highly linear components.

The laser diode is protected both by limiting the drive currents and by sensing the actual light output power of the laser diode. This is expected to improve the reliability of the instrument.

Achieving dependable measurement values demands a certain light distribution within the optical fiber. Special care had to be taken to provide this equilibrium mode distribution (EMD) at the instrument's light output.

Easy handling and error-free setups are facilitated by application-oriented parameter selection, complete specifications, and rigid and accurate fiber optic connectors.

Operating Concepts

The HP 8150A Optical Signal Source incorporates two main parts: an electrical-to-optical transducer and an internal modulation generator. The generator is essentially a pulse/function generator like the HP 8116A,¹ but without an output amplifier. The transducer consists of a laser diode, a regulation circuit, and a programmable optical attenuator.

The HP 8150A operates in either modulator mode or transducer mode. In modulator mode, the HP 8150A performs like a conventional pulse/function generator with an optical output, that is, it provides calibrated level setting, variable timing parameters, trigger/gate modes, submodulation modes, and various waveforms. The front-panel and HP-IB designs are done with the objective of achieving compatibility of the human interface with the HP 8116A whenever possible. Thus a user familiar with this generator is immediately capable of dealing with the HP 8150A (and vice versa). Nevertheless, there are slight differences, which offer some advantages to the operator of the HP

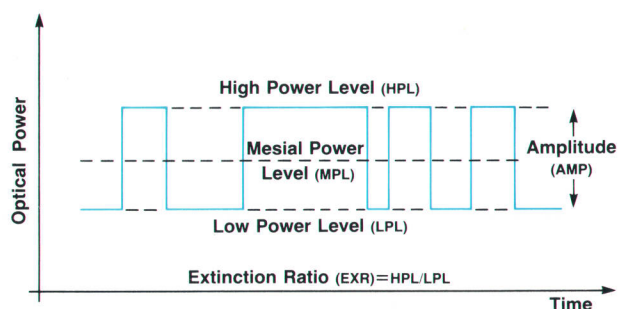

Fig. 2. With internal modulation, the user can modify four parameters of the optical signal. These are the high and low levels, the mesial level, and the extinction ratio.

8150A. One is random access to any function (one key, one function). In the case of senseless settings, the user is not bothered with a confusing multitude of blinking lights, but the entry is accepted and the instrument continues to operate with a meaningful setting, which is indicated by the front-panel lights. The senseless entry is stored, however, and becomes active when the proper combination of modes and parameters is selected. Key blinking is reserved for settings that are usually expected to work but don't because the instrument's lack of capability is not self-evident.

The store/recall feature allows the saving and retrieving of eight complete instrument settings. The number of the last accessed set is displayed to provide protection against inadvertent overwriting. The store/recall settings can be accessed in an arbitrary (instead of only serial) order.

Great flexibility is allowed in the power level setting, which can be specified in watts, dBm, or dB relative to a user-definable reference.

In transducer mode, the electrical-to-optical converter is disconnected from the internal modulator and direct-driven from an external input. In this mode it is possible to set up a calibrated conversion factor and offset compensation for the external signal source. The bandwidth of 250 MHz allows both analog and digital applications.

Optical Parameters

While modulator mode is active, the user can modify four parameters of the optical signal (see Fig. 2):

HPL: high power level
LPL: low power level

MPL: mesial power level, i.e., (HPL + LPL)/2
EXR: extinction ratio, i.e., HPL/LPL

These parameters are not all independent, so "parameter couples" are defined to inhibit ambiguity. The couples are (HPL, LPL) and (EXR, MPL). Modifying one parameter causes a change of both parameters of the other pair. This will be discussed in more detail later in this article.

User Safety

The HP 8150A is a class 3B laser product. Therefore, some efforts are made to protect the user from hazards. In addition to warning labels, on/off keyswitch, remote interlock, and automatic laser shutoff, a safety task is periodically

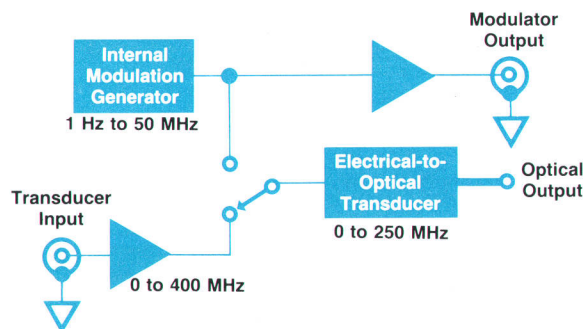
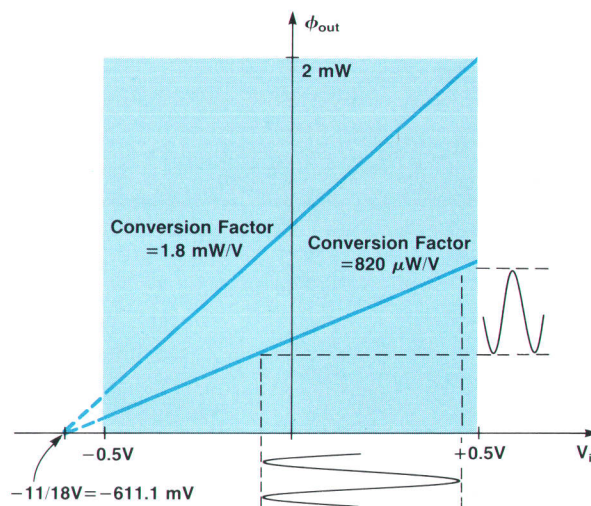

Fig. 3. Simplified block diagram of the HP 8150A Optical Power Source.



$$\phi_{out} = (\text{Conversion Factor})(V_{in} + 11/18V)$$

Fig. 4. With external modulation, the user can select the conversion factor in milliwatts, microwatts, or nanowatts of optical output per volt of electrical input.

performed by the microprocessor. The processor checks the laser shutoff hardware, the output shutter, and the remote interlock switches for proper function. In the case of any malfunction, the processor disables the optical output and the laser, initiates an error message (local and remote), and inhibits any operation of the instrument.

Self-Test

A built-in self-test permits an automatic functional check of the HP 8150A assemblies. The tested groups are the microprocessor system (keyboard, display, RAM), the modulator (frequency and width generator), the transducer (stability, settling time, laser), and the safety interlocks (optical shutter, auto shutoff, remote interlock).

The test is executed each time the instrument is turned on or a special test command is sent via the HP-IB. The optical part of the self-test is also performed each time a laser off-on transition is detected. This happens, for example, when a fiber cable is connected to the instrument.

Another feature, useful for diagnostics and troubleshooting, is direct access. This is the initiation of a read or write operation to the microprocessor system or processor-accessible hardware. For instance, it is possible to transfer a machine language test routine to the RAM and start its execution via the HP-IB.

Block Diagram

The block diagram of the HP 8150A is shown in Fig. 3. The modulation generator, a 50-MHz pulse/function generator adapted from the HP 8116A,¹ produces sine, triangle, square, and pulse waveforms up to 50 MHz. It provides for internal and external triggering, internal and external gating, external pulse width control, and various submodulations: AM, FM, VCO, and PWM (pulse width modulation).

In modulator mode, this generator section is connected to the electrical-to-optical transducer. In this configuration

the HP 8150A acts as an optical pulse/function generator with a fiber optic output. The user can select any modulation waveform in the frequency range of 1 Hz to 50 MHz, or no modulation, which gives a CW (continuous wave) light output. The large dynamic range of the light power (1 nW to 2 mW) is achieved mainly with an attenuator, which is described later. A supplementary output (**MODULATOR OUT**) on the rear panel shows the electrical signal as generated by the modulation generator. This is useful when doing comparative measurements (e.g., time delays, fidelity of signal shape, etc.).

In transducer mode, the generator is disconnected and the electrical-to-optical transducer is connected to a broadband preamplifier which handles the input signal applied to the **TRANS D IN** connector. In this mode one can apply any waveform between dc and 250 MHz to modulate the optical output. Since the instrument has no information about the input signal, the user selects the differential efficiency of the electrical-to-optical transducer as a conversion factor in mW/V, μ W/V, or nW/V. This means that an electrical input swing of 1V results in an optical power swing of the value displayed on the front panel (see Fig. 4). To accommodate various input signals, including ECL levels, the normal input window of ± 0.5 V can be shifted by an additional ± 1.2 V by selecting offset compensation (**OFFS COMPS**). Another task of the preamplifier section is to limit the output signals supplied to the electrical-to-optical transducer so as not to overdrive the laser diode even with excessive input signals. This section also allows for normal/complement switching.

Electrical-to-Optical Transducer

The electrical-to-optical transducer converts its input signals within a ± 0.5 V window into the optical equivalent and allows for further attenuation. The two main sections are the laser section, which provides driving, control, and

protection of the laser diode, and the attenuator section, which attenuates the light power from the laser diode by means of passive attenuators. Fig. 5 is a block diagram of the transducer. In the laser section, the laser diode converts electrical current into optical power. The laser diode is a CW type with a double heterostructure of GaAlAs. It emits a multimode spectrum in the near infrared region at 850 nm (for comparison, the visible range of light lies within 380 and 780 nm).

The laser diode is a very powerful component. This type of diode allows fast modulation up to the GHz region while achieving high output powers (up to 10 mW). LEDs, on the other hand, are either fast or deliver high power, but not both.

The conversion curve (light flux versus current, Fig. 6) shows an important property, namely a threshold current that has to be exceeded to achieve laser operation. Below the threshold, the laser diode acts as an LED with uncorrelated, spontaneous light emission. This means that there has to be enough bias current to push the laser diode into the lasing region, and that there is a pedestal value of light power below which we cannot go.

On the other hand, there exists an upper limit of maximum light power out of the laser diode which must not be exceeded for reasons of lifetime. The dynamic range for our laser is therefore restricted to about 10 (ratio of highest allowable light power level to lowest possible light power level). This value is called the extinction ratio (EXR) and is characteristic of any laser diode. The large dynamic range of the instrument as a whole, therefore, has to be accomplished by additional passive attenuation.

Although powerful in some ways, the laser diode is also a rather delicate part. Figs. 7a and 7b show typical variations of laser diode light flux versus temperature and lifetime. Two means are used to stabilize the laser diode against variations of temperature. First, the heat sink tem-

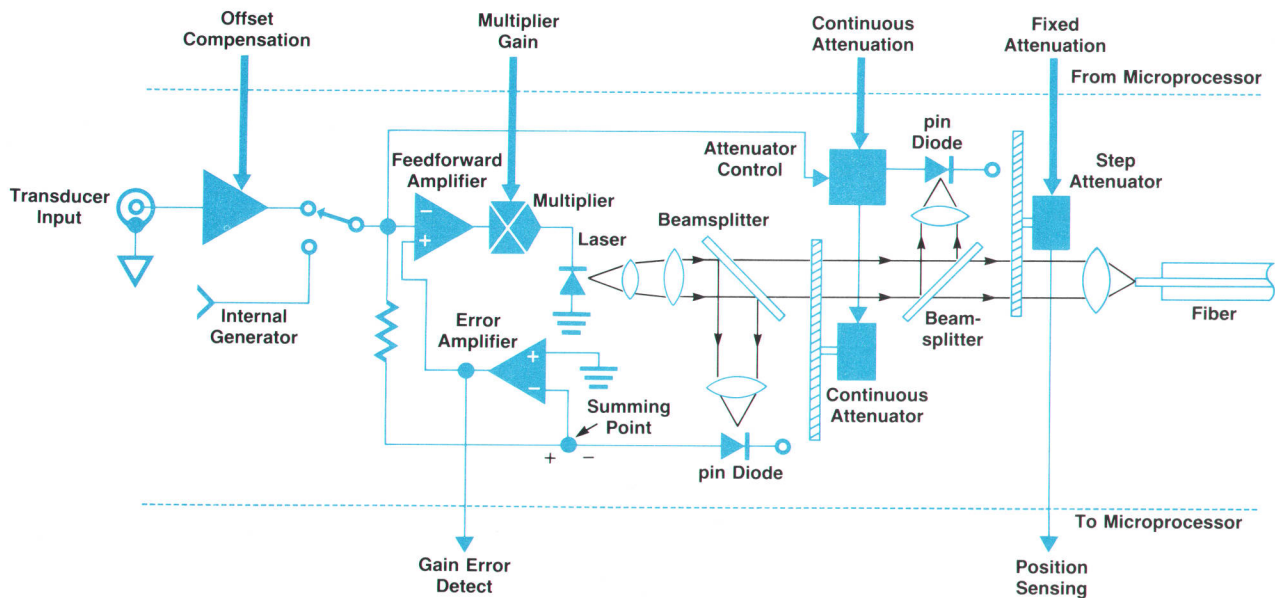

Fig. 5. Block diagram of the electrical-to-optical transducer. Light emitted by the laser diode is controlled by various attenuators and feedback loops.

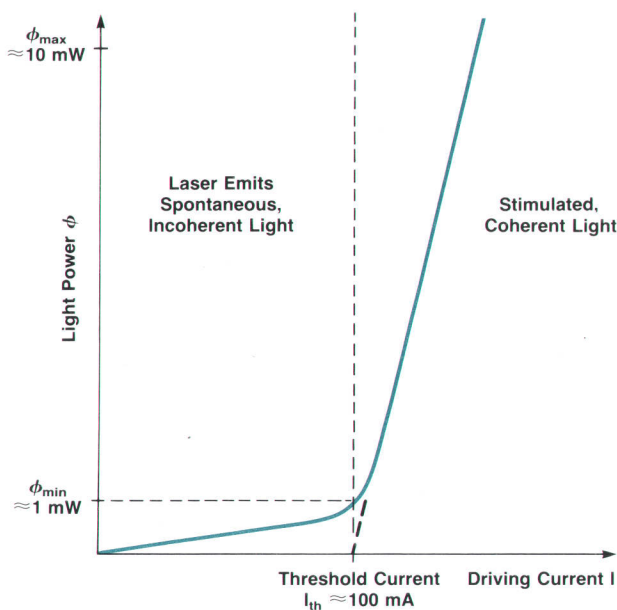

Fig. 6. Typical flux-versus-current curve for a gain-guided laser diode. Note the minimum, or pedestal, light power ϕ_{min} .

perature of the laser diode is held constant. This is done by mounting the laser on a thermoelectric cooler (Peltier element) and controlling its temperature by a special regulator section (see Fig. 8). This suppresses variations in the ambient temperature and therefore greatly increases laser lifetime, which is an exponential function of temperature. Modulating the laser by varying the current, however, means also varying the junction temperature and therefore also has an effect on the laser curve. In purely digital applications this effect can be mostly neglected. However, if we also want the transducer to be highly linear for analog applications, this nonlinear effect has to be compensated. This is the task of the laser control section and is done in an unconventional way (see Fig. 9).

A laser diode emits in two directions. The front beam is normally coupled into a fiber, whereas the back beam falls onto a photodiode within a control loop. Since the front-to-back matching of the two light outputs is typically only within 5 to 10% over the modulation range, this method is not suitable for high-linearity control.

We therefore take a sample of the front light, which eventually is launched into the output fiber. A beamsplitter deflects about 5% of the main beam onto a photodiode. A reference value is derived from the electrical input signal and is connected to the photodiode via a purely resistive network.

In this way, the comparison between actual and reference values involves only highly linear components (beamsplitter, photodiode, resistors). The result is excellent linearity of the electrical-to-optical conversion, since the subsequent error amplifiers are within the feedback loop (see Fig. 9). We achieve not only excellent thermal stabilization but also good linearization of the laser diode within the bandwidth of the control loop (several MHz).

The laser's back-facet radiation is also monitored, as explained later in this article, by a circuit that limits the

laser's light output to prevent damage to the laser.

Laser Gain Control

Closed-loop control up to the upper frequency of 250 MHz, however, is not possible, because the loop bandwidth is limited to less than the bandwidth of the output. Above the bandwidth of the feedback loop the laser diode is driven directly. Great care has to be taken to ensure that the closed-loop low-frequency gain and the open-loop high-frequency gain match perfectly (see Fig. 10). Any change of the laser's characteristics with age will deteriorate this matching. To compensate for this and to maintain near-perfect matching between the two frequency bands, a special laser gain control section has been incorporated. The correction is done under microprocessor control and compensates for any decrease in laser efficiency by increasing the current swing delivered to the laser diode using a gain-controlled differential amplifier.

This section is also able to detect a deteriorated laser diode by noting when the laser efficiency falls below a minimum allowable value.

The matching of closed-loop and open-loop frequency responses is done by modulating the laser with a square wave and monitoring the difference between the nominal and the actual signals.

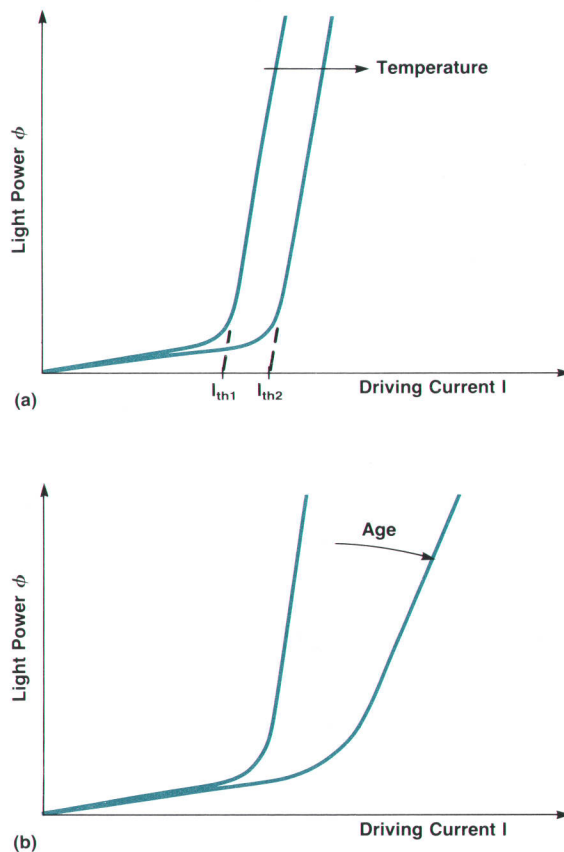

Fig. 7. (a) Temperature dependence of laser diodes. The typical temperature coefficient of the threshold current is $1\%/^{\circ}\text{C}$. (b) Aging behavior of laser diodes. With time, the threshold current increases and the differential efficiency decreases.

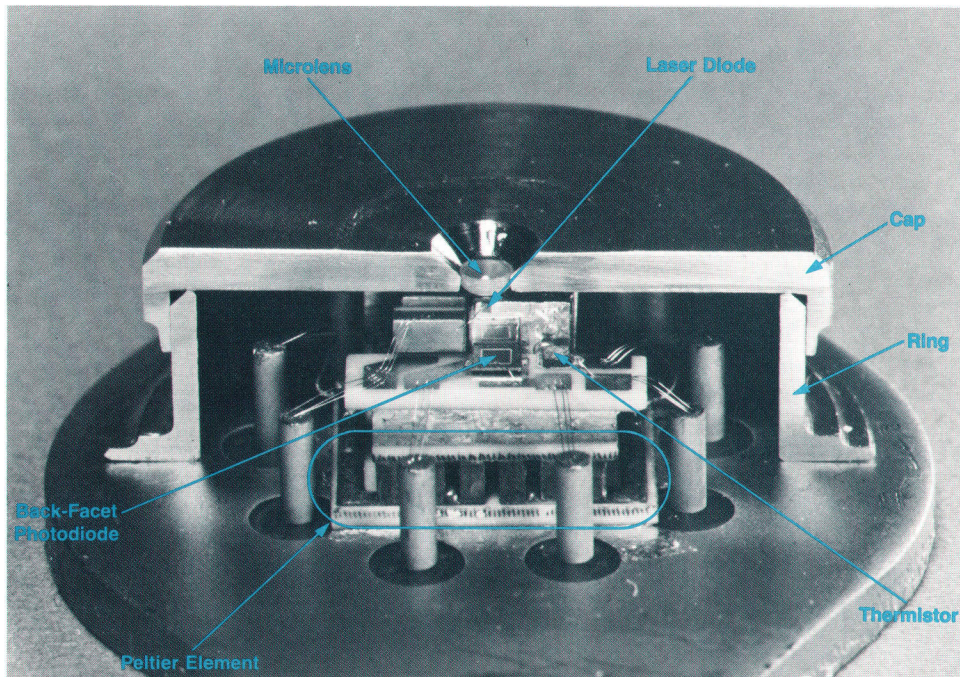

Fig. 8. The laser diode is mounted on a thermoelectric cooler and its temperature is controlled by a regulator circuit. This cutaway view of the laser head shows the Peltier cooler, the photodiode for monitoring the laser's back-facet emission, the thermistor, and the GaAlAs laser diode.

The control loop consists of a sample-hold-compare circuit (see Fig. 11) whose output is fed back to the microprocessor and an adjustable laser current source. Using an algorithm called Fibonacci search, the laser current is adjusted until a relative minimum of the signal difference is found. (The search algorithm is not as quick as simple interval halving, but is more reliable.)

Besides laser gain control, this system provides a criterion for deciding whether the laser is defective or not. For

proper operation the minimum value found by the algorithm is expected to be in a certain range. An out-of-range value indicates a defective laser.

This check takes a few seconds and cannot be executed during normal operation because it may cause an undesirable output signal. On the other hand, the check should be performed as often as possible to guarantee the instrument's specifications. As a compromise, an optical self-test is performed each time the instrument is turned on or a

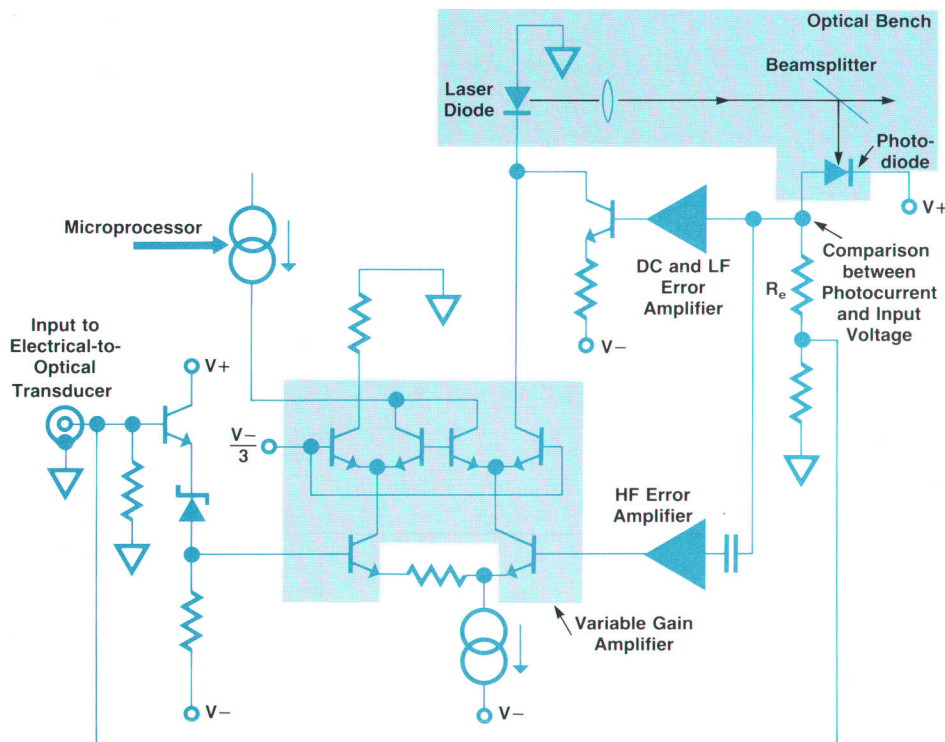

Fig. 9. Simplified schematic of the laser control section that compensates for laser nonlinearity. The front-facet laser radiation (i.e., the actual laser output) is sampled by a beamsplitter and a photodiode. Only highly linear components are used at the error node (comparison point).

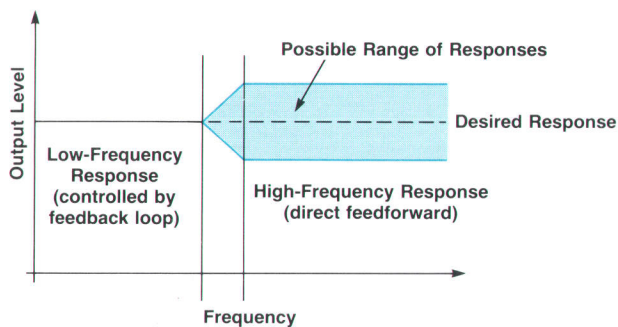

Fig. 10. The laser control section provides closed-loop control of the laser output up to the loop cutoff frequency. Above the loop bandwidth, laser control is open-loop. The closed-loop and open-loop frequency responses must be carefully matched. This is done by a separate laser gain control section.

fiber optic cable is connected.

If a self-test is initiated via the HP-IB, the optical output is disabled and brought back to its pretest condition after the self-test has been completed.

Attenuator Control

As mentioned earlier, modulation of the laser diode can only vary the light power by a factor of 10 (10 dB). To obtain an additional 60 dB of attenuation, further passive attenuation is required. This attenuation is performed in two steps (see Fig. 5). A continuously variable neutral density filter provides attenuation values between 0 and 20 dB, and a three-step attenuator provides fixed values of 0 dB, 20 dB, and 40 dB.

Selecting the first pair of optical output parameters (HPL and LPL) will influence both the laser modulation and the passive attenuation. Since the laser characteristic only allows a dynamic range of 10 dB, there is an automatic adjustment of one level if the user tries to adjust the other level so that it exceeds this limitation. Suppose the instrument is set up at HPL = 750 μ W and LPL = 90 μ W. The user now changes the high power level to a new value of HPL = 1 mW. Together with LPL = 90 μ W, this would require a dynamic range of 10.5 dB (or EXR = 11.1), which can't be obtained. Therefore, LPL will be adjusted so that it re-

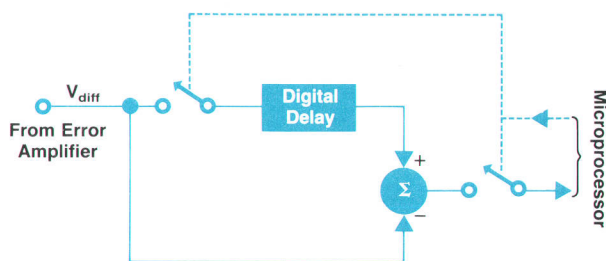

Fig. 11. Matching of closed-loop and open-loop frequency responses is done by modulating the laser with a square wave and monitoring the difference between the actual and the nominal signals. The major element of the control loop is this sample-hold-compare circuit. The microprocessor reads its output and adjusts the laser current to find the minimum of the difference signal.

mains within the limits, that is, it will be automatically set for LPL = 100 μ W.

The same adjustment occurs if one goes below the lower limit, which is the case at an EXR of 1.18. Fig. 12 shows the allowable range of level settings.

This type of level setting is most convenient for checking levels and thresholds. For applications where attenuation, for example in fibers, is the main concern, the other type of level setting (MPL and EXR) is more convenient.

MPL is a kind of average power, but unlike an average, it is independent of duty cycle. Regardless of the waveform, changing MPL means altering the attenuation of the entire optical signal with the other parameter, EXR, remaining constant. Changing the extinction ratio, on the other hand, doesn't change MPL, but controls the relative swing or modulation index m of the signal. These terms are related as follows:

$$m = (EXR - 1) / (EXR + 1)$$

or

$$EXR = (1 + m) / (1 - m)$$

This type of level setting influences the hardware very straightforwardly. The MPL controls the passive attenuation, and the EXR changes the laser modulation.

To achieve high accuracy and stability, the attenuation must be controlled precisely. The step attenuator consists of two pairs of neutral density filters on a filter wheel. It is swung into the optical path by a step motor. This can be done accurately and with high repeatability, so there is no need for further control. Even the tolerances of the filters don't have to be very tight, because small variations can be compensated by the continuous attenuator.

The continuously variable attenuator is realized by a metal-coated glass disc with the attenuation varying over the angle of rotation. To achieve high resolution, a dc motor was chosen as the driving element. For high accuracy and stability, the position of the motor, and therefore the attenu-

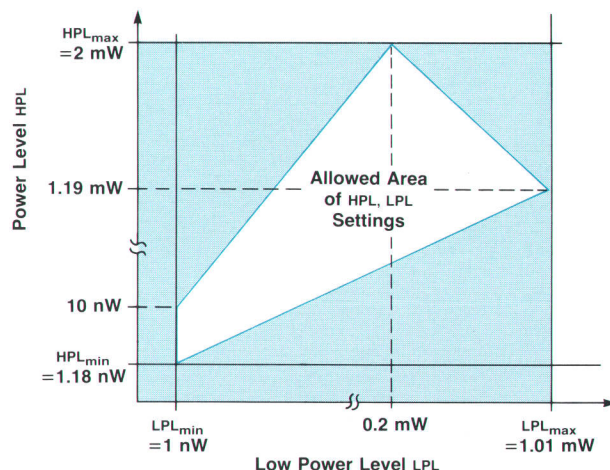

Fig. 12. Range of possible high and low power level settings. Automatic adjustments occur internally to keep the HP 8150A's operation in the allowed range.

ation of the filter disc, is controlled by another loop (see Fig. 5).

A beamsplitter similar to that used for the laser control system sits behind the continuous attenuator and deflects 5% of the transmitted beam onto a photodiode. This signal is compared with a reference signal derived from the input signal of the electrical-to-optical transducer. It is important to note that both signals contain ac components (if the laser output is not CW). This ac comparison makes the control loop duty-cycle-independent. Comparing the deflected signal, which carries the laser modulation, with a fixed dc value would be much easier, but the attenuator control would tend to remove the modulation at low frequencies where the speed of the dc motor is high enough to follow these error signals.

The attenuation of the filter is changed by changing the reference value for the control loop, which is done by a multiplying digital-to-analog converter (DAC). 10-bit resolution is required for one 10-dB range (e.g., from 10 μ W to 100 μ W).

Applying this method over the entire 20-dB range of the filter disc would require at least 14-bit resolution. To avoid the need for such a high-resolution DAC, the 10-bit resolution of the reference DAC is increased by changing the amplification of the photodiode path by a factor of 10.

Optical Bench

The laser light is controlled and attenuated within a miniature optical bench (see Fig. 13). A solid metal block carries the optical elements such as lenses, beamsplitters and attenuators. The design of this bench is discussed later in this article.

The divergent light cone out of the laser diode is collimated by a lens system, with the first lens being part of the laser diode package. The parallel beam is guided through the bench and is finally focused onto the output fiber. To achieve the required light distribution within the fiber, this launching approximately obeys the 70% rule, which means the spot size on the fiber end is 70% of the fiber diameter and the launching aperture is 70% of the numerical aperture of the fiber. For our graded-index multimode fiber, a spot size of 35 μ m and a launching cone with an angle of 16 degrees has to be obtained. This yields an approximate equilibrium mode distribution (EMD), which is further improved by a mode filter within the output fiber. Fig. 14 gives typical results of the near and far fields of the fiber output, which show that the field distribution is very close to the EMD obtained after a 1-km fiber length.

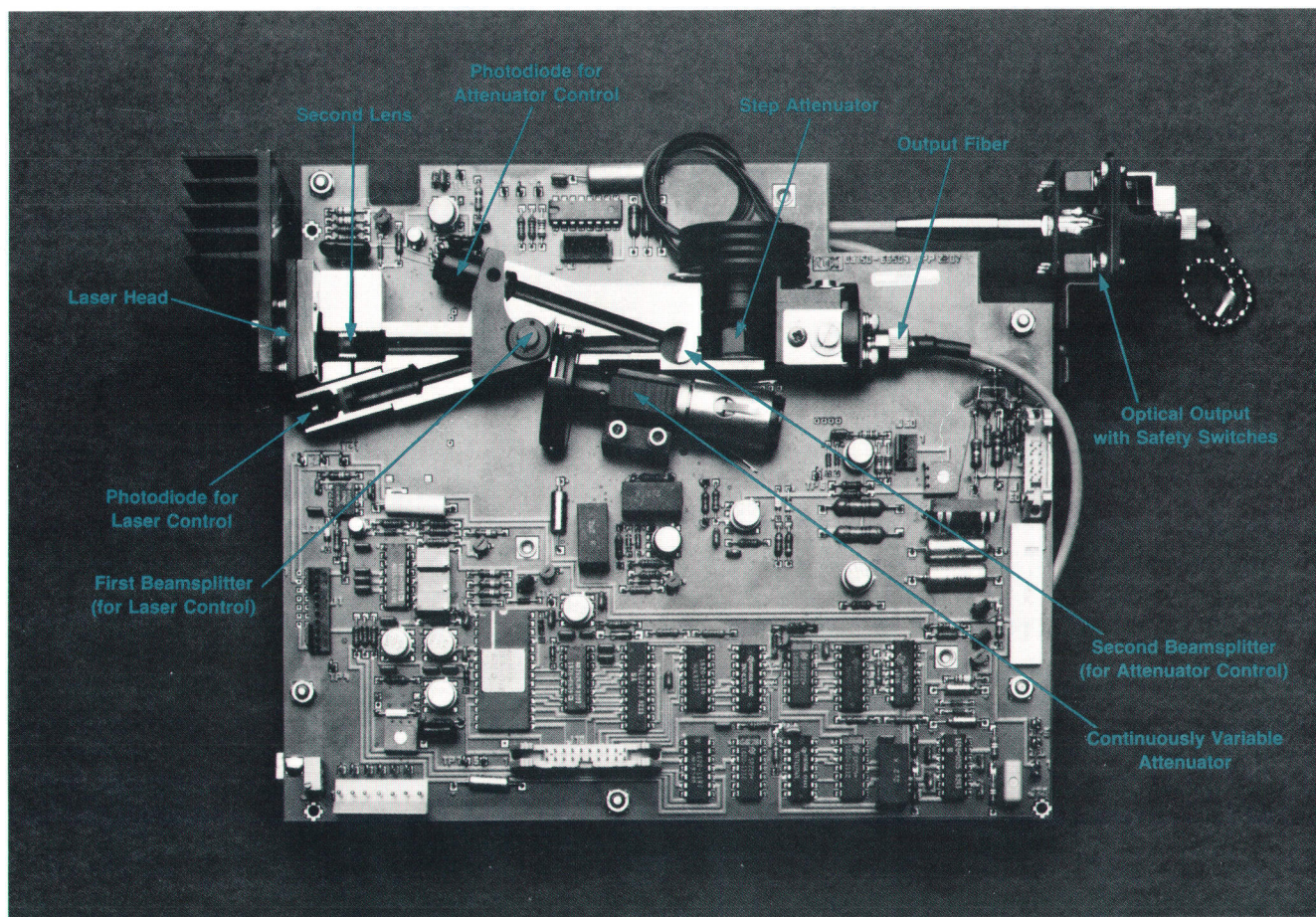

Fig. 13. The laser light is controlled and attenuated within this miniature optical bench. A solid metal block carries the optical elements.

Laser Protection Circuit

To prevent overdriving the laser diode, all voltage and current sources around the laser diode are limited. Furthermore, the laser driver circuitry is powered from only one supply voltage (-15V) to avoid problems caused by different settling times of the power supply voltages.

However, laser diodes are mainly destroyed by mirror damage, which is caused by too much light power. Thus the best and most direct protection is to limit the output power of the laser diode. This is done with a special protection circuit, which is simple, reliable, and fast (see Fig. 15).

A photodiode is mounted within the laser package and senses the back-facet radiation of the laser diode. If the maximum limit is exceeded, a shunt transistor parallel to the laser diode becomes conducting, thus drawing excessive current away from the laser diode. Since only emitter followers are used, the speed of the circuit is limited only by the time constant of the photodiode capacitance and the sensing resistor R_s , which can be kept small. Bypass transistor Q23 allows the circuit to be active even during power-up and power-down.

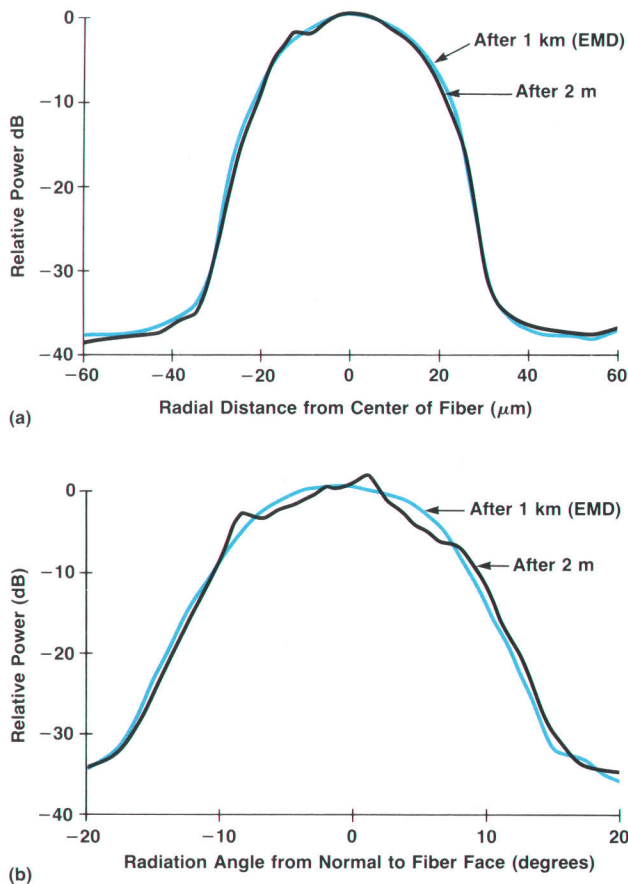

Fig. 14. (a) A near-field scan of the mode distribution 2 meters from the HP 8150A output shows excellent matching with the desired equilibrium mode distribution measured after a 1-km fiber. (b) The far-field scan also shows good matching with the equilibrium mode distribution. The ripple is caused by the speckle pattern on the fiber end, a result of the coherent light of the laser diode.

Laser Safety Circuit

To prevent any unintentional radiation at the light output, the instrument is equipped with two independent types of safety circuits, which shut off the light output when no optical cable is connected (see Fig. 15). This is done by switching off the laser diode and interrupting the light beam within the optical bench by a mechanical shutter.

For reliability, a mechanical approach with double switches is used for sensing. These switches are pressed back when a fiber optic connector is inserted. The laser diode can then be activated, but the mechanical shutter still interrupts the beam. A separate key (**DISABLE**) has to be pressed to remove this shutter and get light into the fiber. This is also the case after switching on the instrument. This disable function can also be performed via the HP-IB.

An additional property mandated by international safety requirements is the remote interlock capability, which has the same effect as the disable function, but acts independently and directly shuts off the laser diode. An external cable loop can be connected to a rear-panel outlet (**REMOTE INTERLOCK**). When this loop is interrupted, it switches off the laser diode, since it is in series with the front-panel switches. The external loop might be connected to a remote switch at an entrance door or to an emergency pushbutton.

Optical Bench Design

The main functions of the optical bench are to:

- Collimate the laser beam
- Attenuate the optical signal
- Provide stable coupling into a graded-index fiber with $50\text{-}\mu\text{m}$ core diameter under conditions of shock and vibration and over a wide temperature range
- Ensure an equilibrium mode distribution at the optical output
- Ensure optical output safety with automatic laser shutoff
- Minimize optical losses.

The optical bench consists of two building blocks (see Figs. 13 and 16), the laser head and the optoblock. The laser head contains the laser diode on a Peltier cooler, a back-facet photodiode, a thermistor, and a microlens. The optoblock carries all optical and mechanical components for attenuating and coupling the light into the fiber.

The housing of the laser head consists of a ring and a cap. The cap carries the first collimation microlens. Both parts, ring and cap, are precisely adjusted with respect to the emitting area of the laser diode, which is on the order of $1 \times 5 \mu\text{m}$. This positioning is done actively, by monitoring the procedure by means of TV cameras with the laser emitting. To obtain reliable operation over a long period, adjustment and subsequent laser welding of the housing are done in a dry nitrogen atmosphere.

The second lens of the system is outside the housing but within the laser head carrier. It is preadjusted for the best collimated beam and the entire subassembly is mounted to the optoblock.

The collimated laser beam hits the first beamsplitter. This partly reflecting mirror can be tilted and turned for precise adjustment of the reflected beam onto the first pin photodiode, which measures the light output for the laser control loop. Great care had to be taken to achieve a mode-

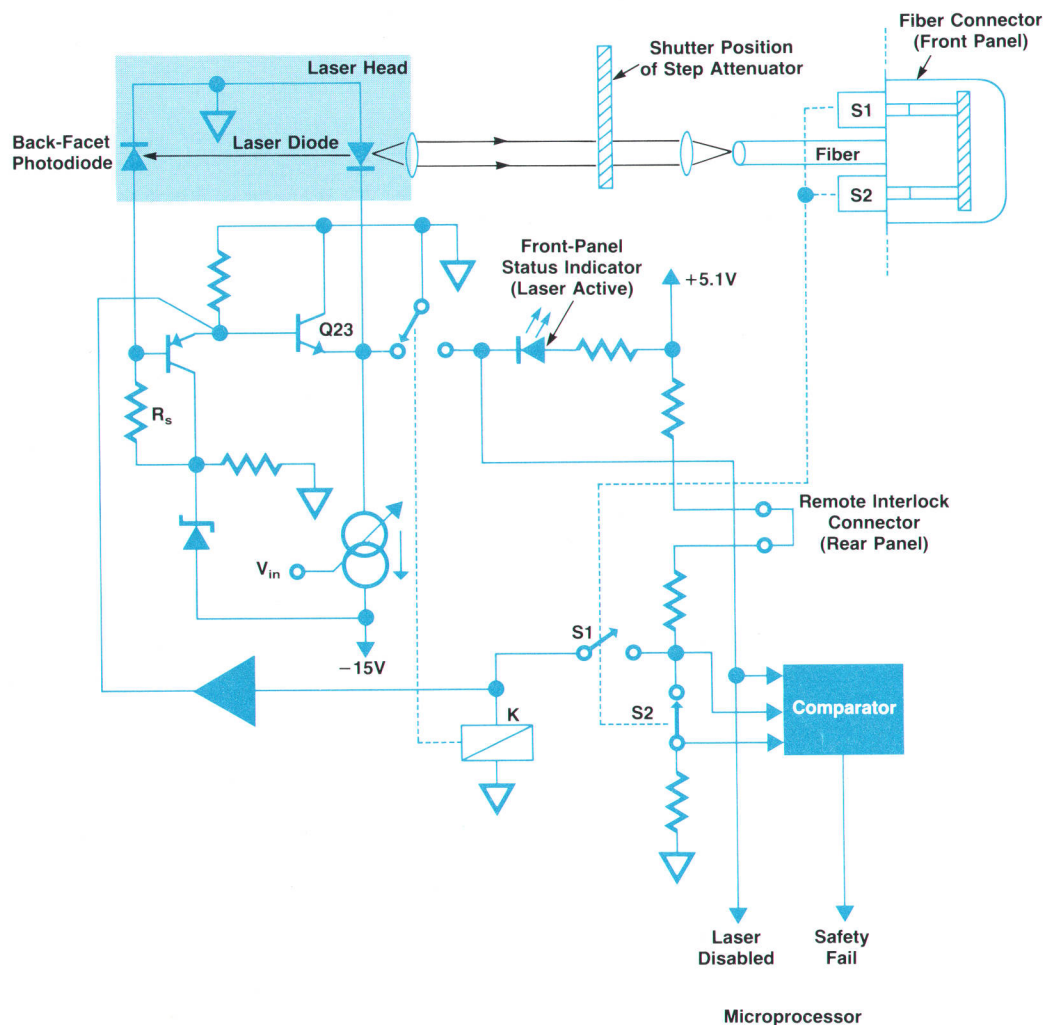

Fig. 15. This laser safety and protection circuit prevents laser damage caused by overdriving the laser. It also shuts off the light output when no optical fiber is connected.

modulation-, and polarization-independent splitting ratio. For instance, the beamsplitter has an angle of less than 10° with respect to the optical axis to avoid polarization-dependent splitting. This is necessary because the ratio between parallel and orthogonal polarization of the laser varies with the modulation of the laser diode.

Coherence of the emitted light power is another problem, since it causes multiple interference within the beamsplitter plate, which can be disastrous, especially in the weak reflected beam. A special form and coating of the beamsplitter plate are needed to overcome these problems.

Behind this first beamsplitter is the continuous optical attenuator. It consists of a glass substrate with a metallic coating whose optical density increases continuously up to 20 dB over the angle of revolution (see Fig. 17). Here again, a special form and coating help to get rid of undesired multiple reflections which otherwise would cause slight nonlinearities over the laser modulation range. The driving element is a miniature dc motor with a tachogenerator and gearbox reduction. A second beamsplitter, identical to the first, and a second photodiode sense the attenuation, and together with the tachogenerator's signal, control the exact

position and thus the optical density of the attenuator.

The next element in the optical path is the step attenuator, which is driven by a step motor and has four positions. A metal wheel with three drilled holes carries four fixed attenuator plates (see Fig. 18). In the first position, no filters are in the light path; this is the 0-dB range. In the second and third positions, two 10-dB or 20-dB filters, respectively, are moved into the optical path. The filters in each pair are slightly tilted with respect to each other to avoid beam deflections and suppress multiple interferences. The fourth position has no hole, and therefore completely interrupts the beam (DISABLE position).

This fourth or reference position is sensed by a small magnet on the filter wheel, which sits opposite a Hall-effect sensor. This magnetic sensing of the position was chosen over an easier optical sensing because of the very high attenuation of this filter. It also allows complete shielding of the optical path.

After this coarse attenuator, the main beam meets the launching lens, which focuses the beam onto the end of the output fiber. To account for mechanical tolerances and variations in the focal length of the lens, this lens can be

(continued on page 18)

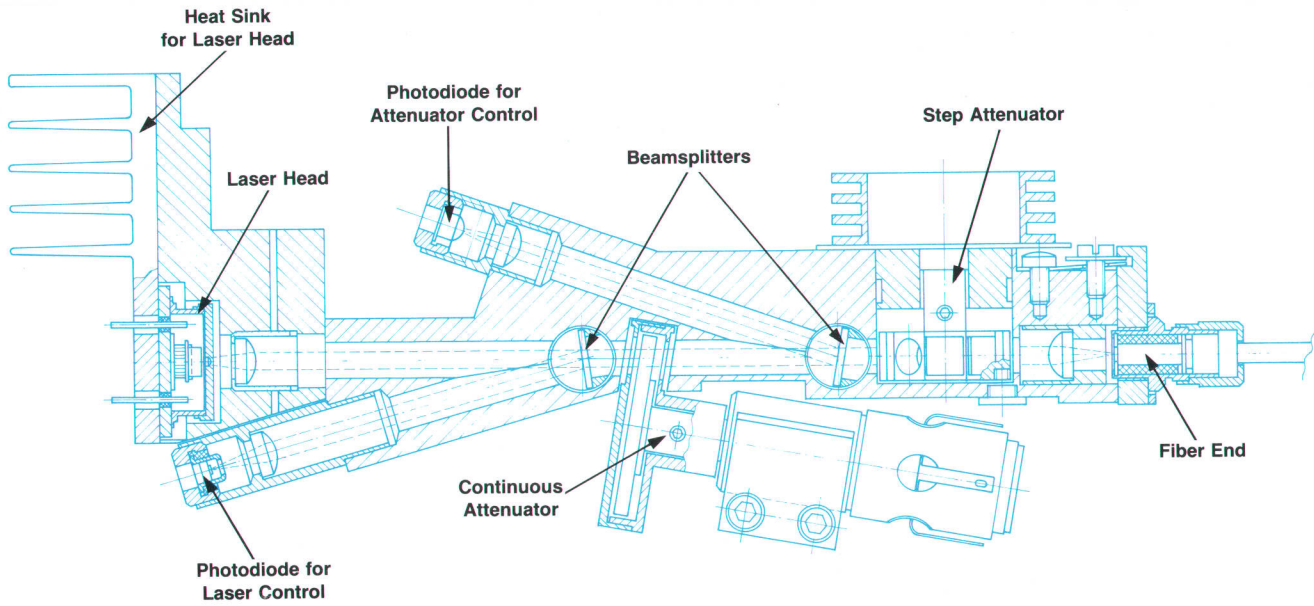

Fig. 16. Cross section of the optical bench.

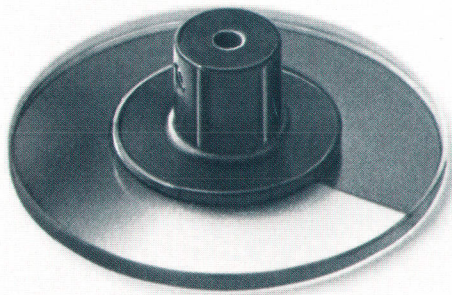

Fig. 17. Continuously variable attenuator disc (0-20 dB).

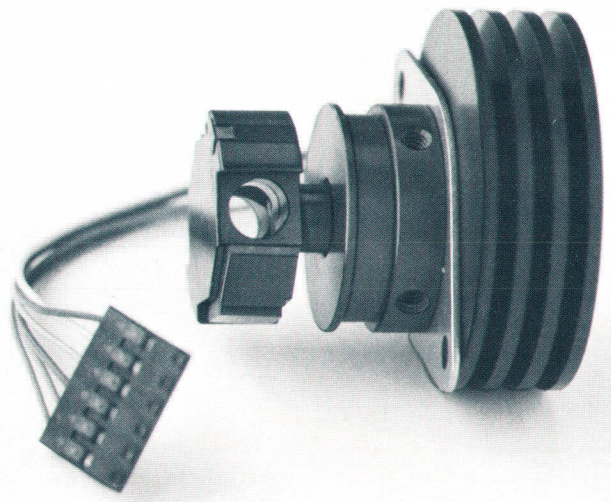

Fig. 18. Step attenuator assembly (0, 20, or 40 dB or ∞).

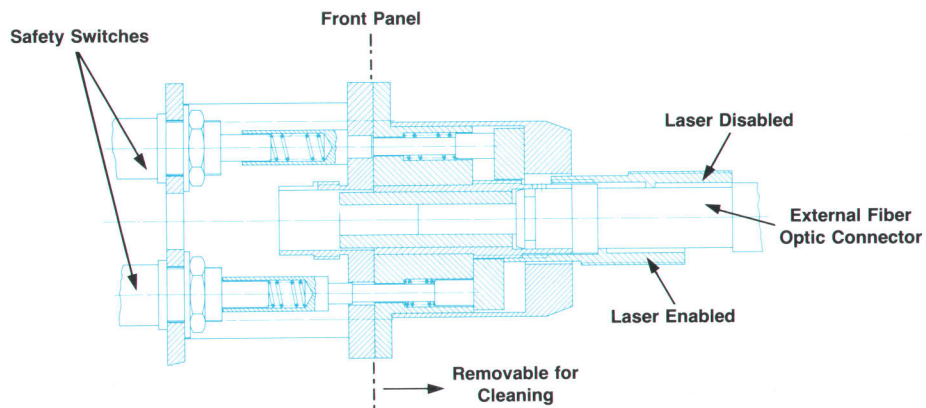

Fig. 19. Cleanable fiber optic output connector with safety switches.

slightly adjusted back and forth. The fiber end is held in a precision hard metal bushing and can be adjusted in the two directions orthogonal to the optical axis. This must be done very precisely and consistently since the focus spot is only 35 μm in diameter on the 50- μm core of the fiber.

The glass fiber between the end of the optical bench and the instrument's output is one meter long and contains an additional mode scrambler and stripper to achieve, together with the 70% launching condition, a good approximation of the desired steady-state equilibrium mode distribution.

The optical output has a safety interlock that prevents any laser light output with no cable connected (see Fig. 19). Two microswitches must be activated by a pressure plate and two tension-guided pins to switch on the laser diode.

To reduce optical losses, all lenses are antireflection-coated. The holes for the optical beams have absorbing surfaces to avoid stray light.

The housing of the optoblock is manufactured as an

aluminum extrusion because of the complicated outer contours. The finish is done on automatic machines with accuracies better than 0.05 mm.

To evaluate thermal expansions, the optical bench was simulated by finite element analysis. The analysis showed excellent stability, which has been verified in production.

Acknowledgments

The authors wish to thank former section managers Christian Hentschel and Werner Hüttemann for many ideas and contributions to the definition of the instrument. Special thanks go to Tom Hornak's group within HP Laboratories. Bill Brown, Don Hiller, Pete Szente, and Russ Riley helped build the first prototype of the instrument in an extremely helpful and unselfish manner.

Reference

1. M. Fleischer, H. Rossner, and U. Neumann, "A New Family of Pulse and Pulse/Function Generators," *Hewlett-Packard Journal*, Vol. 34, no. 6, June 1983.

A Versatile, Programmable Optical Pulse Power Meter

by Werner Berkel, Hans Huning, Volker Eberle, Josef Becker, Bernd Maisenbacher, Wilfried Pless, and Michael Goder

THE HP 8151A OPTICAL PULSE POWER METER (Fig. 1), together with the HP 81511A Optical Head, is a general-purpose fully programmable optical response measuring instrument suitable for the wavelength range of 550 to 950 nm. With the HP 81512A/B Optical Head, the HP 8151A's wavelength range is 950 to 1750 nm.

The HP 8151A can measure the peak (high and low levels) or the average power of optical signals. The upper and lower levels of optical signals are measured and displayed directly without the need to derive such values from average power and a known duty cycle.

The ability to determine peak levels and associated parameters such as amplitude or extinction ratio is useful for testing digital fiber optic systems or characterizing fiber optic components. Direct parametric measurements of level-related data, such as extinction ratio, threshold, or flatness, are possible.

The HP 8151A measures optical power levels over a large bandwidth from dc to 250 MHz within a measurement range of +10 dBm to -20 dBm (optical). For greater sensitivity, down to -60 dBm, bandwidth is reduced to 4 kHz.

The optical pulse power meter incorporates an optical-to-electrical transducer that gives an electrical output signal corresponding to the optical input waveform. This signal can be displayed on an oscilloscope or applied to other

electronic equipment. By means of the transducer, various other parameters besides power levels, such as transition time, signal degradation, pulse width, and flatness can be measured.

The Optical Head

To allow for possible future applications of the HP 8151A Optical Pulse Power Meter under different optical conditions—a different wavelength range, for example—the optical-to-electrical transducer is housed in an optical head, which is connected to the HP 8151A by an interface cable. The optical heads currently available, the HP 81511A (Fig. 2) and the HP 81512A/B, operate over wavelength ranges of 550 to 950 nm and 950 to 1750 nm, respectively. Future optical heads may have different optical capabilities, but will use the same interconnections with the main unit.

To make this possible, the interconnections had to be well-defined, not changeable, and applicable to all types of optical heads. The head had to be given some intelligence for handshaking with the main unit. This is done by five control lines. Three control lines are driven by the HP 8151A and give operating instructions to the head for determination of the measurement range, selection of average or peak measurement, and activation of a shutter for the zero function.

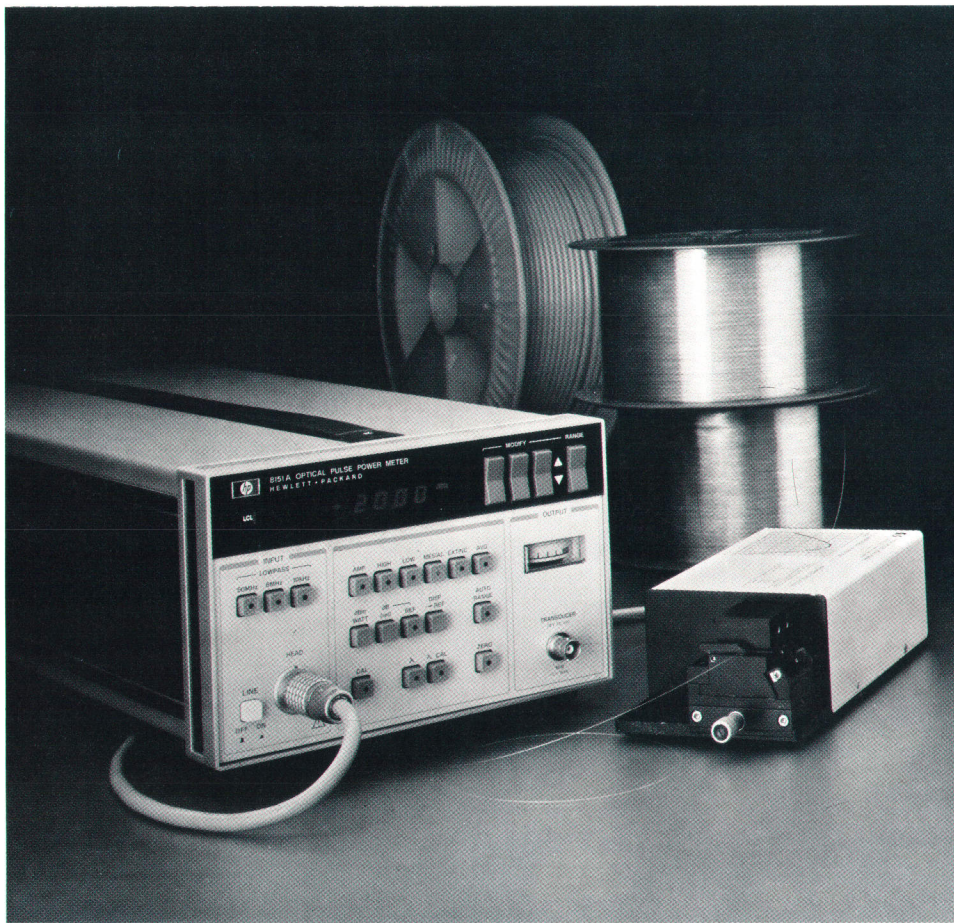

Fig. 1. The HP 8151A Optical Pulse Power Meter (left) measures and displays peak and average optical input power levels. It has a bandwidth of dc to 250 MHz for optical power between -20 dBm and $+10$ dBm. Its optical-to-electrical transducer is in a separate optical head (right) connected by a cable to the mainframe.

The head responds on the remaining two control lines: telling the HP 8151A the availability of a shutter and whether to add a $\times 10$ amplifier to the signal path in the main unit, and reporting the status of the head—what type of amplifier is in use (high-speed or sensitive), whether the motor is active, or if a measurement range has been

selected that the head is not capable of.

The interface cable also contains the power supply lines. One of these is for biasing the pin photodiode with up to 200V of bias voltage. Four more lines are for temperature control, including a separate ground to avoid affecting the signal ground.

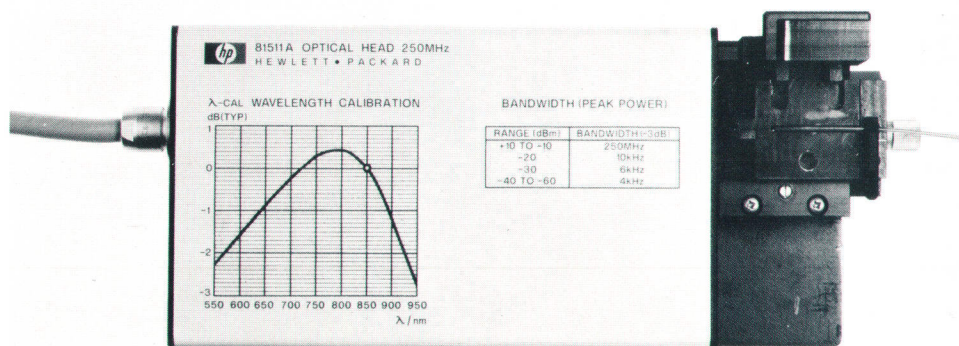

Fig. 2. The HP 8151A Optical Head operates over a wavelength range of 550 nm to 950 nm. The HP 81512A/B (not shown) operates over a wavelength range of 950 to 1750 nm.

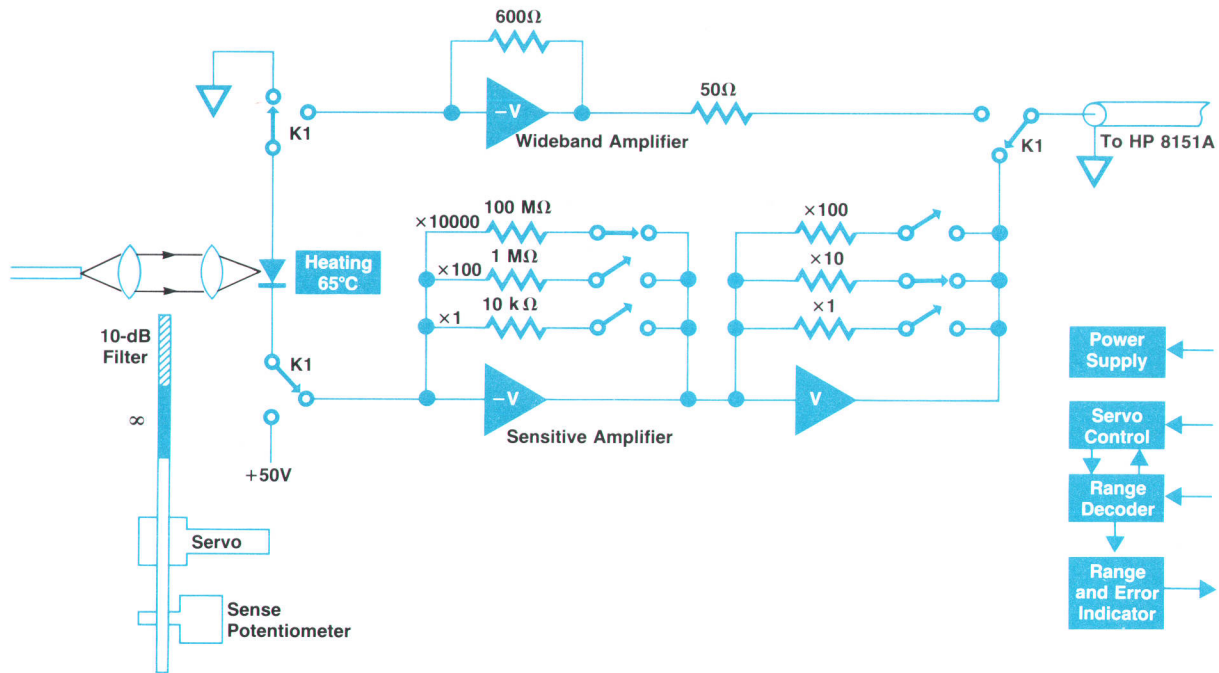

Fig. 3. The HP 81511A Optical Head has a wideband, dc-to-250-MHz path for optical power between -10 dBm and $+10$ dBm, and a very sensitive, narrowband, dc-to-4-kHz path for optical power down to -60 dBm.

Two-Path Concept

It was found that a two-path design was the best solution for the optical head (see Fig. 3). Depending on the selected measurement range and on the measured signal parameter, either a very sensitive bandwidth-limited amplifier or a high-speed wideband amplifier is switched on.

In the HP 81511A, for example, the sensitive path consists of a transimpedance amplifier with switchable trans-

impedances up to 100 M Ω followed by a voltage amplifier with switchable gains up to a factor of 100. For this operating mode the diode is zero-biased, so dark current and noise are held to a minimum. This signal path allows measurements of signals in the pW range up to an optical power of 10 mW. The bandwidth is limited to 4 kHz, 6 kHz, or 10 kHz, depending on the measurement range.

Measurements of light signals modulated with up to 250

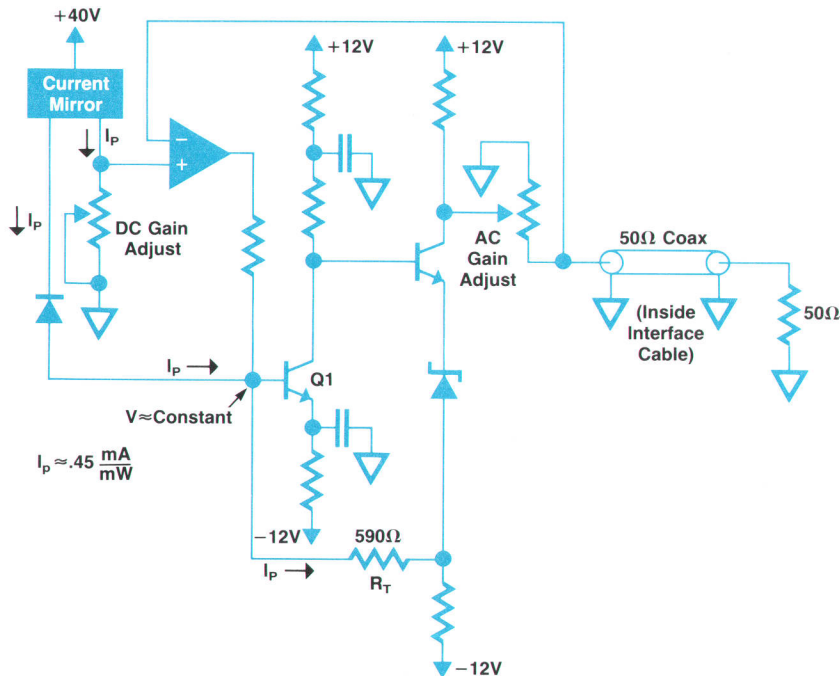

Fig. 4. The wideband transimpedance amplifier in the optical head is fast, offset compensated, and dc coupled.

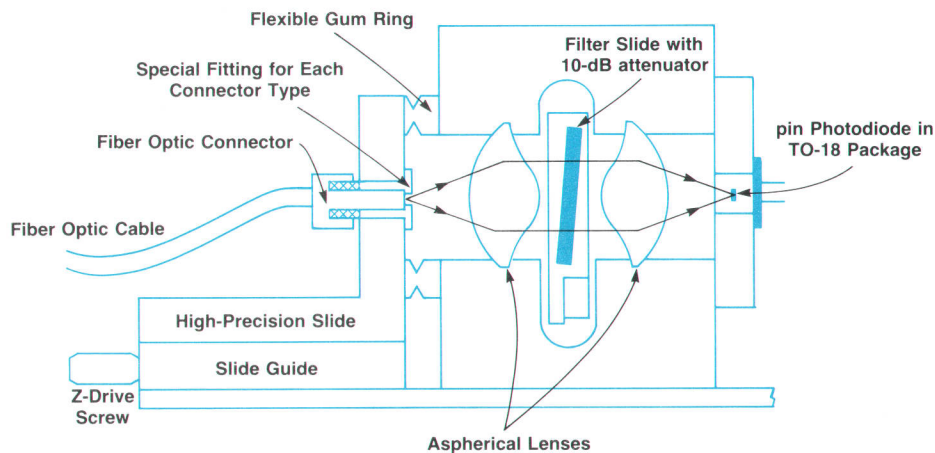

Fig. 5. The HP 81511A Optical Head accommodates different types of fiber optic connectors by using a special fitting for each connector type. The slide carrying the fitting is adjustable with respect to the focal point of the lens system inside the head.

MHz need to reverse-bias the pin diode for more speed, and the transimpedance amplifier needs higher-speed performance. For this kind of application, the high-speed path is used. In the wideband amplifier in this path, the transimpedance is small and not switchable. The basic schematic is shown in Fig. 4.

The pin diode's photocurrent flows through a current mirror, and the mirrored current I_p goes to the reference resistor used for adjusting the dc gain. The output of the amplifier is sensed and compared with the reference voltage to compensate for any output offset caused by drift of the base current of Q1, which would affect the photodiode current I_p flowing through R_T .

This transimpedance amplifier is very fast, offset com-

pensated, and dc coupled, with no discontinuity between dc and ac gain. However, its sensitivity is limited by noise because of its high bandwidth. It is used in the ranges from -10 dBm to $+10$ dBm full scale.

Optical Interfacing

Fiber optic connectors are not yet standardized. Some people want to measure with the bare fiber without any connector. There are also different fiber types in terms of core diameter and numerical aperture.

The optical interface of the optical head accommodates these variables by using different fiber adapters (see Fig. 5). The fiber connector attaches to a fitting which is a special part for each type of connector. This fitting is precisely

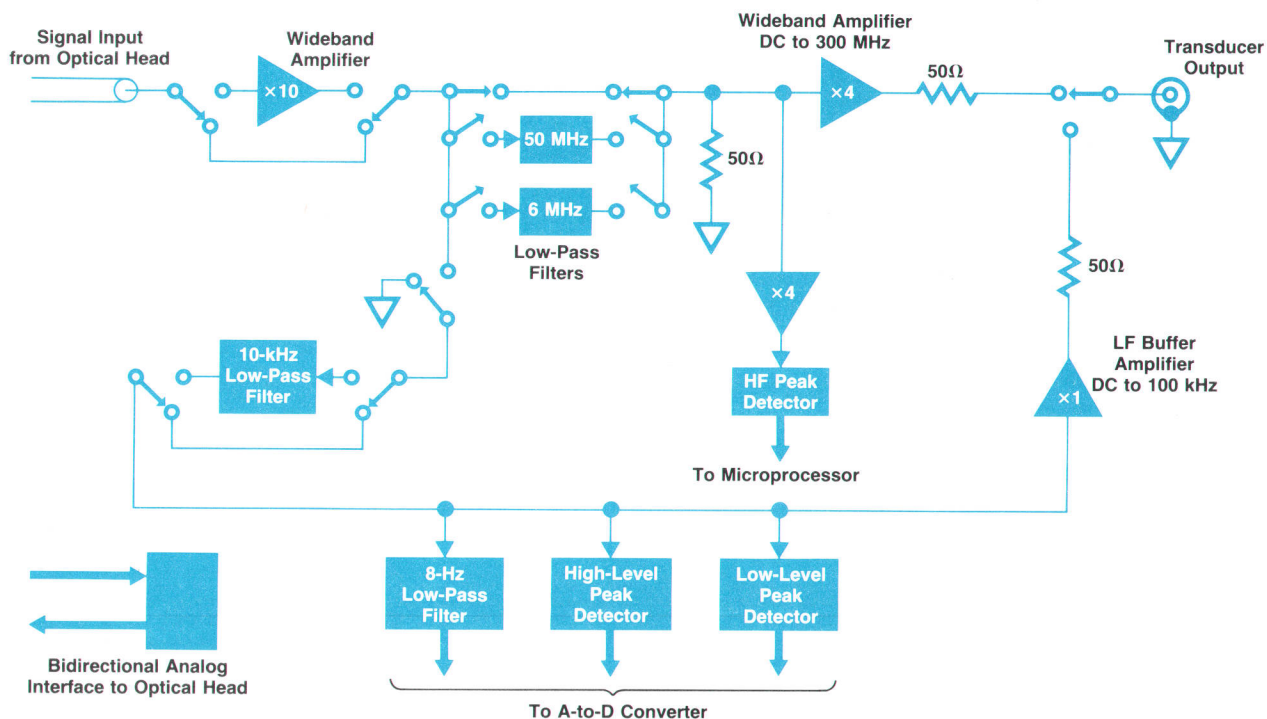

Fig. 6. Like the optical head, the HP 81511A Optical Pulse Power Meter has two paths, a wideband path and a high-sensitivity path. Peak detectors measure the high and low signal levels, and an 8-Hz low-pass filter produces an average signal.

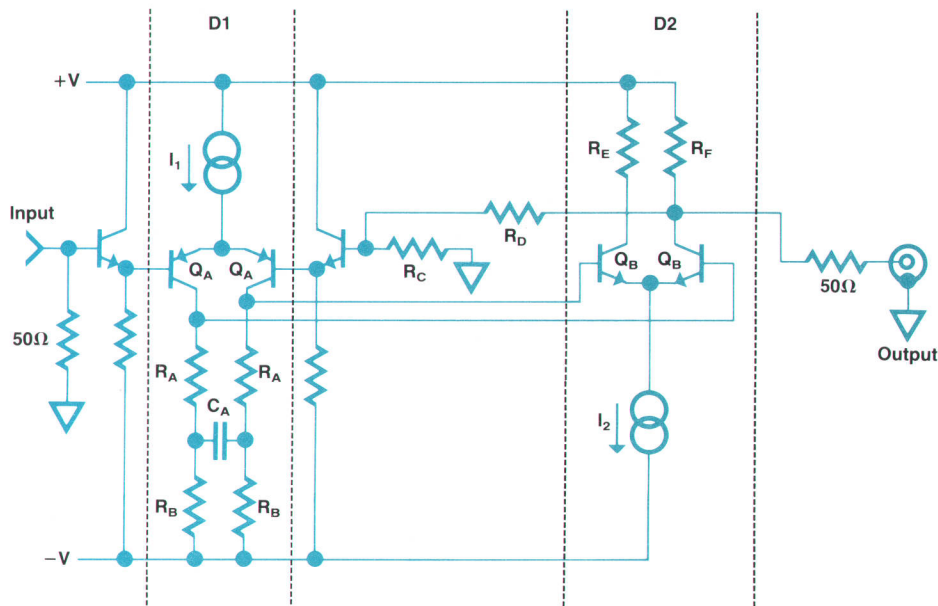

Fig. 7. One of the two identical 6-dB ($\times 4$) amplifiers in the high-frequency path of the optical pulse power meter.

positioned on a high-precision mechanical slide, which is mounted on a slide guide on the front of the head. A Z-axis drive screw adjusts the end of the fiber to the focal point of the lens system inside the HP 81511A and the HP 81512A. In the HP 81512B, which has a 100- μm -diameter GaInAs pin photodiode, an XYZ drive is used for focusing.

The lens system consists of two aspherical lenses and allows the use of fibers up to a numerical aperture of 0.4. The second lens focuses the light beam onto the surface of the photodiode. The magnification of the lens system is set to unity to allow fiber core diameters from 50 μm to 200 μm , depending on the type of head.

For bare fiber applications a special adapter (slide) is

used. The bare fiber fits into a V-groove and is held lightly there, while mechanical stress is reduced by a clamp pressing on the fiber's jacket.

Inside the head and between the two lenses, the light rays are parallel, and an optical attenuator can be inserted here if there is more than 1 mW of light power. A reflection-type optical filter is fixed on a slide driven by a dc motor. In the HP 81511A, the slide has three possible positions: completely open, 10-dB attenuator applied, and completely closed. The first position is used for all ranges but the +10 dBm range. On the +10-dBm range, where signals up to 10 mW can be measured, the 10-dB attenuator is automatically inserted by moving the filter slide to its second position. The third position totally interrupts the light ray so the photodiode does not receive any light. This is necessary for zeroing the system.

The position of the slide is continuously sensed by a potentiometer driven by the slide itself. Thus, each undesired movement of the slide—for instance, the result of a mechanical shock, or incorrect positioning after turning the system on—will be realized and corrected.

The key features of the three optical heads are compared in the table below.

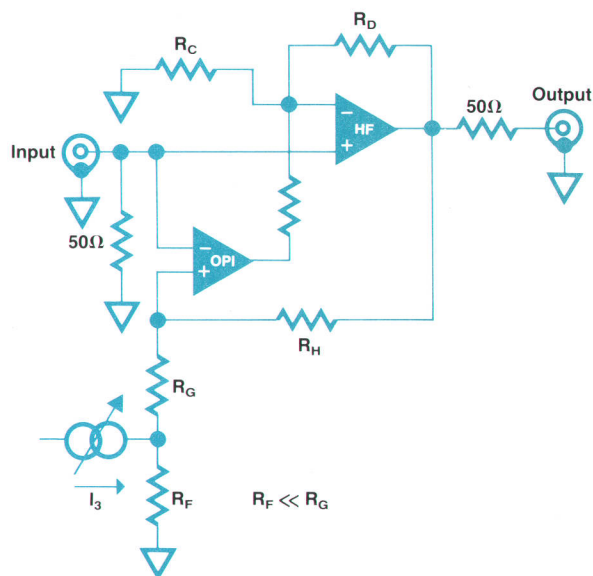

Fig. 8. To control the low-frequency gain of the 6-dB wide-band amplifiers, operational amplifier OPI is added. Low-frequency gain is determined by the ratio R_H/R_G . Current source I_3 is adjusted to compensate for system offsets.

HP 81511A HP 81512A HP81512B

	HP 81511A	HP 81512A	HP81512B
Wavelength (nm)	550-950	950-1750	950-1750
Detector type	Si	GaInAs	GaInAs
Maximum fiber core diameter (μm)	200	200	55
Power range (dBm)	+10 to -60	0 to -50	0 to -60
Bandwidth (MHz)	250	150	250

Power Meter Design

In the HP 8151A Optical Power Meter, the signal from the optical head is directed to one of two paths (Fig. 6). Depending on the measurement range, either the wideband path (10 mW to 100 μW) or the narrowband, high-sensitivity path (lower than 100 μW) is activated. The wideband

$\times 10$ amplifier is inserted in the $100\text{-}\mu\text{W}$ range only. In applications where test requirements call for reduced noise, a 50-MHz, 6-MHz, or 10-kHz low-pass filter can be activated.

In the wideband path, after the low-pass filter, the signal is divided in two and buffered for the transducer output and the high-frequency peak detector (described later).

The sensitive path is activated in the lower power ranges and in average mode. The signal from this path goes to a low-pass filter which produces an average signal, to the high-level and low-level peak detectors, and to a buffer amplifier for the transducer output.

Wideband Pulse Amplifiers

The HP 81511A Optical Head (for example) supplies the HP 8151A Optical Pulse Power Meter with an RF signal of 250 mV amplitude in the upper three ranges (-10 dBm to $+10$ dBm).^{*} This signal forms the input to two identical 6-dB ($\times 4$) amplifiers. One of these drives the high-frequency peak detector and the other drives the analog output of the transducer. This ensures that the output load resis-

^{*}On the -10 dBm range, the HP 8151A switches in a $\times 10$ amplifier to boost the signal to this level.

tance doesn't affect the peak measurement.

As shown in Fig. 7, each of these 6-dB amplifiers consists principally of two differential amplifiers, D1 and D2. D1 is driven by the constant current I_1 (50 mA) and has an open-loop amplification factor of 50. The high-frequency gain of this stage is reduced by R_A and C_A , the cutoff frequency being primarily determined by the time constant of R_A and C_A . Two input emitter followers raise the input resistance by the current gain factor β .

The collector potential of transistor pair Q_A controls the second-stage differential amplifier D2, which consists of transistor pair Q_B , which is driven by the constant current source I_2 (125 mA). This stage is asymmetrical because the output voltage is proportional to the light power, which is always positive. The open-loop gain is about 200. The output signal is fed back via R_D to the complementary input of D1. The resistance ratio of R_D/R_C determines the closed-loop gain of this amplifier.

To control the low-frequency gain, an operational amplifier OPI is added (see Fig. 8). The low-frequency gain is determined by the ratio R_H/R_G . It is possible to compensate for the offset voltages of the system by adjusting the current source I_3 .

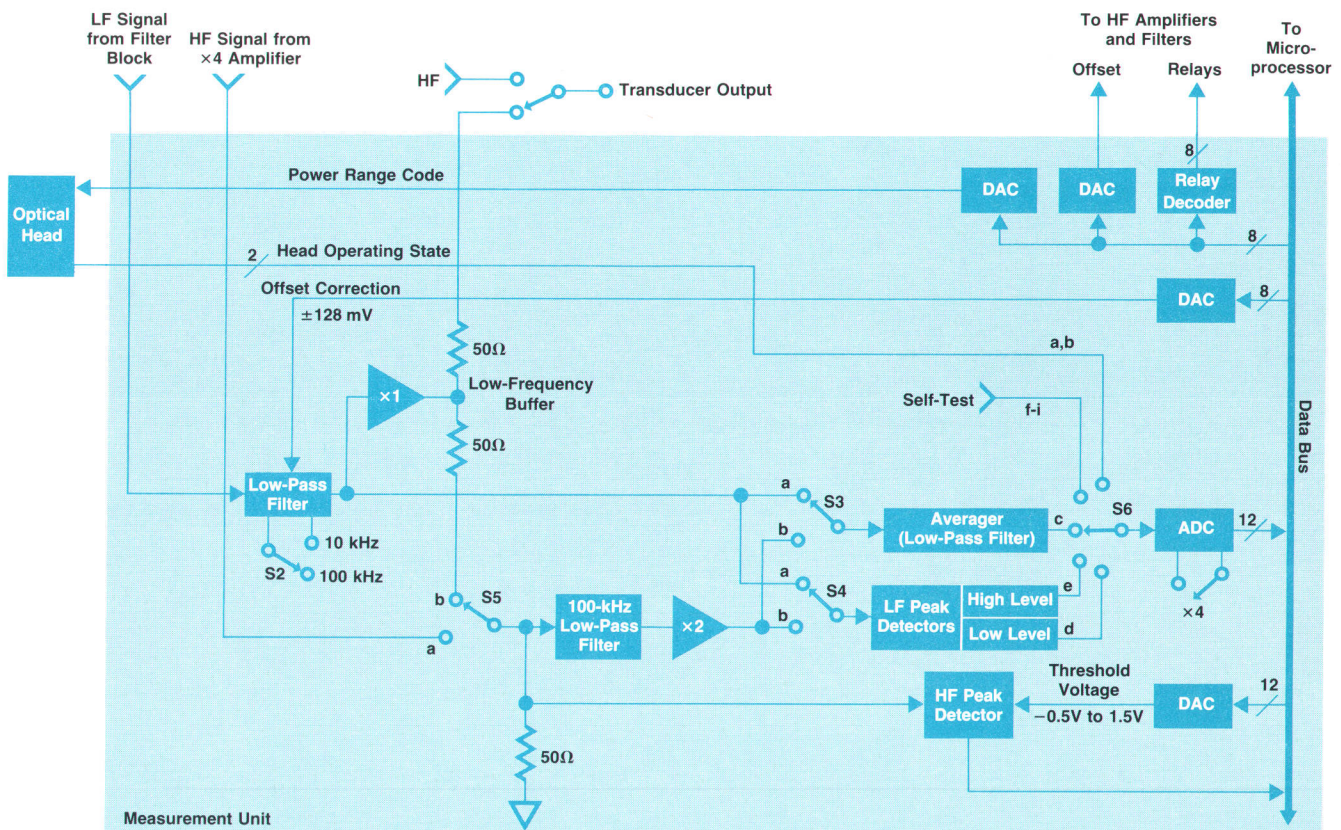

ADC=Analog-to-Digital Converter
DAC=Digital-to-Analog Converter

Fig. 9. In the measurement unit of the HP 8151A Optical Pulse Power Meter are the filters, peak detectors, digital-to-analog converters, and analog-to-digital converters that perform all of the analog and digital signal processing in the instrument.

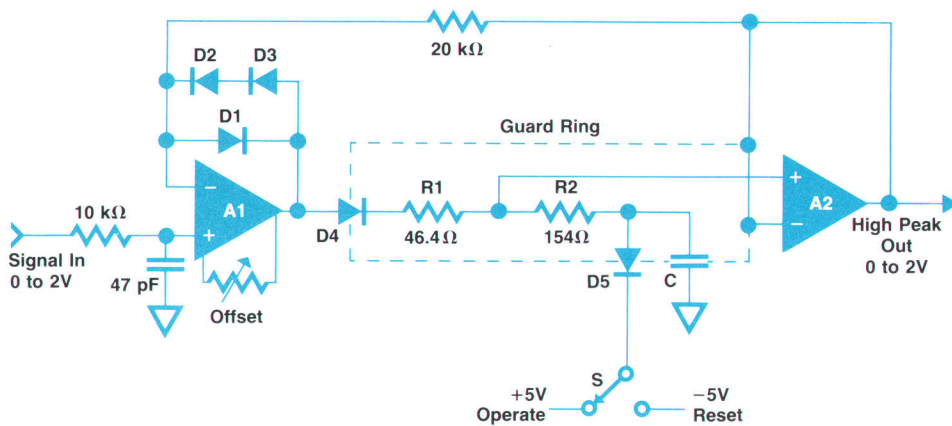

Fig. 10. Schematic diagram of the analog peak reader that detects the high peak level in the low-frequency path of the HP 8151A. For the low peak reader, all diodes are reversed.

For good flatness, care had to be taken to equalize critical time constants. Also important are an optimal layout and the use of chip components for R_A , R_C , and C_A . Several adjustment points are necessary to compensate component tolerances for optimal pulse performance. The typical 3-dB corner frequency of this amplifier is 320 MHz.

Measurement Unit

The measurement unit is the interface between the optical head and the microprocessor. It performs all analog and hybrid signal processing in the HP 8151A.

As the signal flow diagram (Fig. 9) shows, there are two inputs, LF and HF. Signals originating from the optical head on a high-sensitivity range, having limited bandwidth, are routed directly to the LF input. The maximum allowable bandwidth here is 100 kHz. The corner frequency can be switched to 10 kHz by switch S2 to limit detector noise interference at very low light levels. The signal format is 0 to 2V for 100% of range, from a low-impedance source to a high-impedance input. Dark offset, drift, and peak noise of $\pm 20\%$ will be accepted without causing an overload condition.

On the broadband ranges, the optical head delivers smaller amplitudes of 250 mV or 25 mV for full scale. These signals are amplified 4 or 40 times, respectively, in the wideband amplifiers described earlier, before they arrive at the HF input. The signal format here is then uniformly 0 to 1V, from 50 Ω into 50 Ω , again with $\pm 20\%$ offset and peak noise tolerance.

Outputs from the measurement unit consist of digitized

information concerning high power level, low power level, and average level. Amplitude, mesial, and extinction values are calculated from the high and low power levels by the microprocessor.

All control signals for the high-frequency circuits (ranging relays and offset correction) and the optical heads (selection of amplifier, attenuator, shutter, and range) are decoded or generated in the measurement unit. The optical head identification and operating state signals to the HP 8151A mainframe are also digitized here.

Averager and Low-Frequency Transducer

Because the low-frequency detector electronics in the optical head covers the full dynamic range with the best accuracy, information on the signal average is derived from this path in all power ranges. To compensate for dark current and other electronic offsets, a dc current is introduced in the 10-kHz/100-kHz low-pass/buffer stage (Fig. 9) while the detector is held at a dark condition by the motor-driven shutter described earlier.

The signal is then branched to the averager, the low-frequency peak detectors, and a current booster (low-frequency buffer), which provides a low-distortion 50 Ω transducer output.

The averager is a four-pole Bessel filter with $\times 5$ dc amplification to match the 10V input scale of the analog-to-digital converter (ADC). Features of the averager include the ability to follow signal frequencies up to the maximum refresh rate (4 Hz), suppression of ac signals of 50 Hz and higher by 60 dB or more, and the ability to provide a flicker-

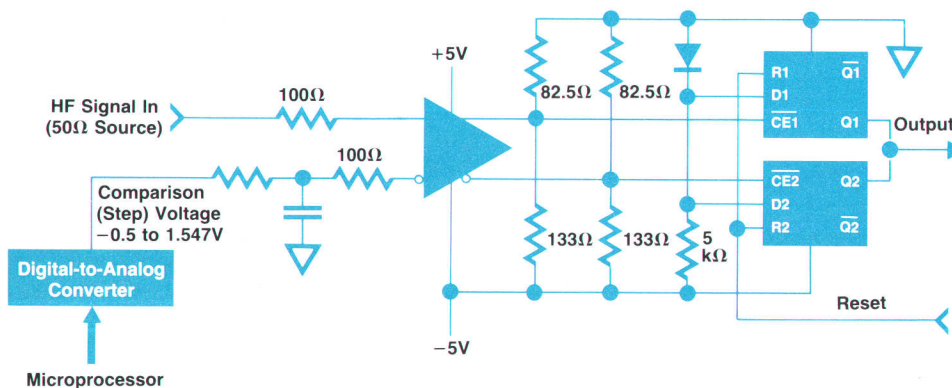

Fig. 11. High-frequency peak detector circuit. This circuit can detect pulses as narrow as 4 ns at a repetition rate as low as 200 Hz.

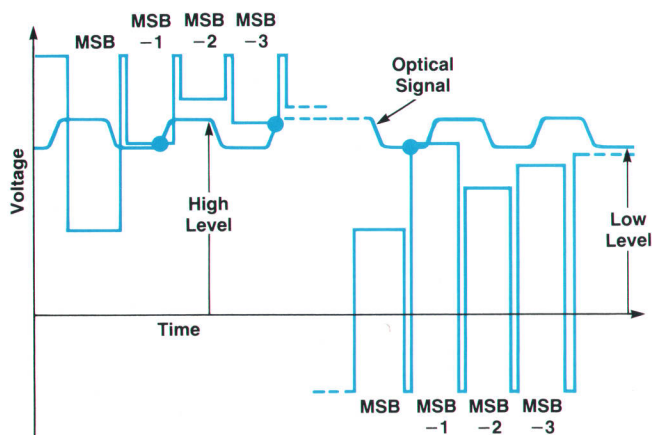

Fig. 12. Using the high-frequency peak detector, the microprocessor executes an algorithm similar to successive approximation to find the highest and lowest peaks of the input signal.

free display of the average value, even with signals swinging from zero to full scale. The average signal is monitored by a meter on the front panel.

Low-Frequency Peak Detectors

The high peak level and the low peak level of LF signals are determined by analog peak readers. These are track-and-hold circuits with some refinements to raise their frequency limits (50% cutoff) to beyond 100 kHz. The stored peak values are amplified five times before analog-to-digital conversion.

The high peak reader circuit is shown in Fig. 10. For the low peak reader, all diodes are reversed. Clamping diode D1 prevents saturation of operational amplifier A1 during the hold phase; this eliminates storage delay. D2, D3, and R1 limit the charging current of the hold capacitor C in the track phases, again preventing overdrive of A1. Stability of the feedback loop around A1 and A2 is improved by R2 for smooth, fast tracking. Droop is minimized by appropriate guarding and by D5, a low-leakage diode like D4, which isolates the analog reset switch S from the hold capacitor C.

Analog-to-Digital Conversion

For output from the measurement unit to the data bus, the signal from analog multiplexer S6 in Fig. 9 is digitized linearly with steps of one half of a display unit. To ensure adequate resolution in logarithmic display modes (dBm and dB), a $\times 4$ preamplifier stage is automatically inserted whenever the signal level falls below 21% of range. This stage is bypassed again when the signal rises above 25% of range.

In addition to measuring the average and LF peak signals, the measurement unit ADC and multiplexer are used to read the operating state of the optical head, which is coded in two voltages. In addition, some critical reference and signal voltages are checked in a self-test routine during automatic zero-adjust phases.

High-Frequency Peak Detector

This circuit (see Fig. 11) is activated in the broadband power ranges, -10 dBm to $+10$ dBm. It is able to detect pulses with 4-nanosecond minimum pulse width at a minimum repetition rate of 200 Hz. This means a duty cycle of 1:1,250,000 or, on the other hand, a maximum frequency of about 100 MHz at 1:1 duty cycle.

The signal arriving at the HF input is routed to a high-speed comparator (Fig. 11). The comparator compares the input signal with a reference voltage produced by a digital-to-analog converter (DAC) driven by the microprocessor. The comparator has complementary ECL outputs. A transition in the states of these outputs occurs if the input signal crosses the reference level in either direction during the comparison time. Depending on the direction of the transition, one of two D-type positive-edge-triggered flip-flops will be set. The outputs of these flip-flops are wire-ORed. Their combined output tells the microprocessor whether or not a comparator transition occurred during application of a given comparison voltage. If two or more transitions occur, only the first affects the output. The flip-flops and the DAC are reset before a new comparison voltage is applied. The speed of this circuit is limited only by the combination of the comparator and the flip-flop.

The microprocessor executes an algorithm similar to successive approximation to find the highest and lowest peak levels of the input signal (see Fig. 12). The difference between this algorithm and successive approximation is the short reset between each bit approximation. These resets generate the transitions needed for the edge-triggered flip-flops to detect a dc input signal.

Like the successive approximation method, this algorithm has a constant conversion time. For estimation of each bit of the 12-bit DAC, 5 ms is allowed. Thus the minimum input signal repetition frequency is 200 Hz. A complete peak measurement takes $12 \times 5 = 60$ ms, and to measure both the high and the low peak levels takes 120 ms. The high and low peak levels include noise and other disturbances on the input signal. To eliminate these effects, a self-calibration routine is provided to subtract the noise from the signal. The high-frequency peak detector is also used to check signal peak levels for autoranging and overload/overrange.

Microprocessor Functions

The HP 8151A uses a microprocessor to perform various functions. Among these are:

- Controlling various measurement sequences
- Performing numerous calculations and corrections (e.g., power level calculations and noise correction)
- Providing internal self-test
- Performing a self-calibration routine, which eliminates offset voltages on signal paths and determines noise amplitude for level correction
- Monitoring the optical head interface
- Controlling the HP-IB interface.

Parameter Computations

The microprocessor calculates optical power levels in dBm, dB, and watts, taking into account the reference level and the calibration factor. From the high power level (HPL)

and the low power level (LPL) measured by the peak detectors, it computes amplitude (AMP), mesial power level (MPL), and extinction ratio (EXR), as follows:

$$\begin{aligned} \text{AMP} &= \text{HPL} - \text{LPL} \\ \text{MPL} &= (\text{HPL} + \text{LPL})/2 \\ \text{EXR} &= \text{HPL}/\text{LPL} \end{aligned}$$

Calibration factor (CAL) and reference level (REF) are taken into account as follows:

PD = displayed power
PI = input power in watts

$$\begin{aligned} \text{PD}(\text{watts}) &= 10^{((10 \log \text{PI} - \text{CAL}(\text{dB}))/10)} \\ \text{PD}(\text{dBm}) &= 10 \log (\text{PI}/1 \text{ mW}) - \text{CAL}(\text{dB}) \\ \text{PD}(\text{dB}) &= 10 \log (\text{PI}/1 \text{ mW}) - \text{CAL}(\text{dB}) - \text{REF}(\text{dBm}) \end{aligned}$$

On each measurement cycle, the HP 8151A measures HPL and LPL, computes AMP, MPL, and EXR, converts all power levels to dBm and dB, and displays the results. To achieve an acceptable display refresh rate of 3 Hz, a table-driven linear-to-logarithmic conversion is used. Converting one parameter from watts to dBm and dB takes approximately 7 milliseconds. The total computation time for all five parameters is about 50 ms.

Self-Calibration

Offsets of buffers, amplifiers, and active filters and noise contributions of active and passive elements of the optical head, the RF board, and the measurement unit board cause erroneous power readings. The self-calibration routine, ac-

tivated by the **ZERO** key or by HP-IB command, reduces these effects. Because noise and offsets are heavily dependent on the transducer path and the power range, the calibration routine determines noise and offset corrections for each range and path. A change of range, transducer, or filter causes a software routine to pick the corresponding correction values from a buffer, apply the offset value to an offset DAC, and provide the noise correction value to be added to the measured low power level or subtracted from the measured high power level.

When the self-calibration routine is initiated, the shutter in the optical head moves into its disable position so that incident light is blocked and the only signals remaining in the system are caused by offsets and noise.

In general, offsets are measured using a 6-Hz low-pass filter and an ADC. The result is applied to the offset DAC and the process is repeated. This continues (see Fig. 13) until the remaining offset is less than a preset value, and then the resulting correction value is stored in a matrix buffer. If the remaining offset is not within the preset limit after a certain number of steps, or if it is larger than a fixed voltage, an error message is generated.

System noise is measured using the peak detectors with the optical input disabled. As shown in Fig. 14, the high power level of a measured signal with noise superimposed is too high by one half the noise amplitude, while the low power level is too low by the same amount, assuming that the system noise is signal-independent white noise. The self-calibration routine measures the high and low peak levels of the noise and stores a value equal to one half the difference between them in the matrix buffer as the correction value for the range, transducer path, and filter in use.

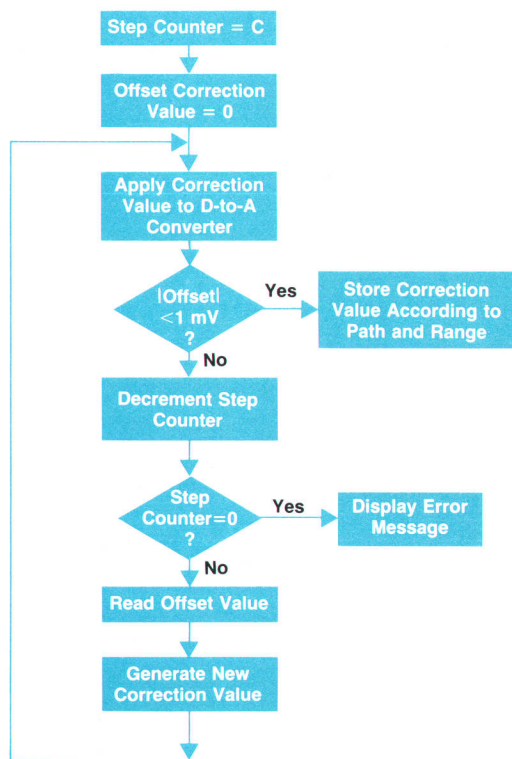

Fig. 13. Flow chart of the offset determination routine.

Self-Test

The self-test package is valuable in production and service support, where it speeds up troubleshooting. The self-test always runs when the instrument is turned on or when the command EST (execute self-test) is received via the HP-IB; no keyboard operations are required. The self-test routine tests the keyboard, RAM, DACs, ADCs, peak detectors, averager, and signal/measurement paths. If any test fails, an error code in the display indicates which part is defective. If the RAM test fails, the test program goes into an endless loop.

Testing the signal/measurement paths is easy because there are relays to isolate these paths from the incoming signal. After this is done, the offset DAC at the input amplifier is used as a signal source. This signal has to be measured correctly by the measurement circuits to pass the test.

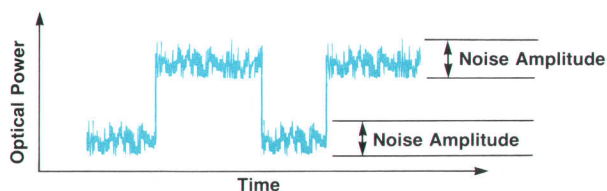

Fig. 14. Optical input signal disturbed by noise.

Acknowledgments

Special thanks to Christian Hentschel and Joachim Feld, who had the original idea for the instrument, and to Rudi Voszdecky, who was responsible for the mechanical design

of the power meter, optical head, and accessories. Joachim Feld also served as project leader for the HP 8151A and did much of the design.

An Optical Receiver for 550 to 950 nm

This versatile front end expands the measurement capabilities of electronic test equipment into the fiber optic domain.

by Michael Fleischer-Reumann, Emmerich Müller, and Gerd Koffmane

THE MINIMUM INSTRUMENTATION necessary to begin making measurements in the fiber optic domain is an optical-to-electrical transducer, since once the optical signal is converted to an electrical signal, measurement equipment for nearly every parameter or application is available. The HP 8151A Optical Pulse Power Meter described in the article on page 18 contains such a transducer, along with specialized measurement circuitry. In parallel with the HP 8151A, a stand-alone transducer with enhanced performance, the HP 81519A Optical Receiver (Fig. 1), was developed for those who want only this

capability. The HP 81519A has a calibrated conversion gain of -1V/mW , which means that a combination of the HP 81519A and a simple voltmeter allows one to do dc or average optical power measurements with an accuracy of $\pm 0.3\text{ dB}$ (optical) over a temperature range of 0 to 55°C .

For high-frequency or pulse performance measurements, the HP 81519A provides a 400-MHz bandwidth for optical-to-electrical conversion and a 1.1-ns intrinsic pulse transition time. Good pulse performance goes along with these specifications, so the HP 81519A is also suitable for analog measurements in which a flat frequency response is required or where the pulse shape contains the signal information and not only its digital high and low levels.

The HP 81519A is also recommended for measurements with network analyzers, and because of its low harmonic distortion, with spectrum analyzers. Input offset compensation provides a convenient way to adapt the HP 81519A's operating range to the optical input conditions. Network and spectrum analyzers sometimes require a dc-free input signal, whereas the optical signal always consists of an optical power offset and ac modulation. With offset compensation, optical input power offsets ranging from 0 mW to 1 mW can be set to 0V output voltage. In addition, this compensation expands the input power range from 1 mW of optical amplitude to a maximum power level of 1.5 mW, as shown in Fig. 2.

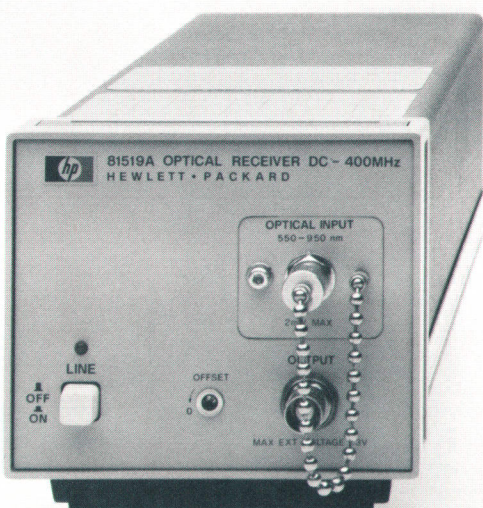

Fig. 1. The HP 81519A Optical Receiver converts optical power to electrical signals with a calibrated conversion factor of -1V/mW . It operates over an optical wavelength range of 550 nm to 950 nm and has an electrical bandwidth of dc to 400 MHz.

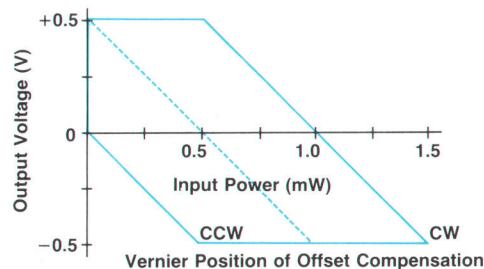

Fig. 2. Offset compensation allows adjustment of the input power that produces a 0V output.

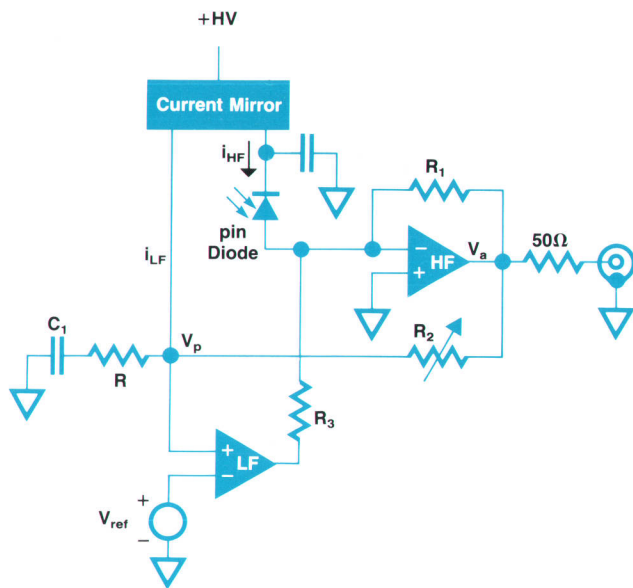

Fig. 3. The optical-to-electrical transducer uses a pin photo-diode working into a transimpedance amplifier. The amplifier has two paths, one for high frequencies and one for low.

An advantage of the new optical receiver is its low noise level. The equivalent noise input power is less than 700 nW at the full signal bandwidth of 400 MHz. This means that even small signals can be detected.

Splitband Design Approach

For use as a measurement instrument, the optical-to-electrical transducer had to fulfill many different requirements:

- High frequency range
- Stable transducer gain with time, temperature, and component variations
- Low distortion
- Low noise.

To meet these goals, a pin diode working into a transimpedance amplifier was chosen as the best compromise. The block diagram is shown in Fig. 3. The amplifier has two paths, one for high frequencies and one for low. This splitband design achieves both high speed and low drift.

The anode of the pin diode is connected to the inverting

input of a high-frequency amplifier, so that the photocurrent i_{HF} is converted via R_1 to the voltage

$$V_a = -i_{HF}R_1 \quad (1)$$

A second signal path only for low frequencies achieves low temperature drift and is formed by the current mirror and the low-frequency amplifier. The current mirror supplies the pin diode with reverse voltage (+HV) and applies the low-frequency component of the converted optical signal to the second conversion resistor R_2 , where high-frequency and low-frequency conversion are adjusted to match. With this resistor connected to the high-frequency amplifier's output, the voltage at the noninverting input of the low-frequency amplifier is

$$V_p = i_{LF}R_2 + V_a \quad (2)$$

V_a consists not only of the value given by equation (1), but also an error voltage V_{err} caused by drift or other nonideal characteristics of the high-frequency amplifier. Therefore,

$$V_p = i_{LF}R_2 - i_{HF}R_1 + V_{err} \quad (3)$$

Taking the low-pass filter RC_1 into account, we can see that the low-frequency amplifier compares V_p to the reference voltage V_{ref} at its inverting input and injects a correcting current via R_3 into the inverting input of the high-frequency amplifier. It also supplies the bias current for the high-frequency amplifier's input stage. The input offset compensation described above is performed by varying the reference voltage V_{ref} .

High-Frequency Feedback Amplifier

The high-frequency amplifier achieves both stable gain and low distortion. Fig. 4 shows a more detailed schematic. This amplifier consists of two stages, a transimpedance stage (Q1,Q2) and a postamplifier stage (Q4,Q5,Q6). Two emitter followers, Q3 and Q7, provide the necessary current gain and decoupling of the stages.

These circuits are implemented with discrete devices (a hybrid circuit or custom IC would have increased the cost). Therefore, achieving good pulse performance required careful layout to avoid parasitic capacitances and phase shifts.

For example, in the postamplifier, a bandwidth of 400

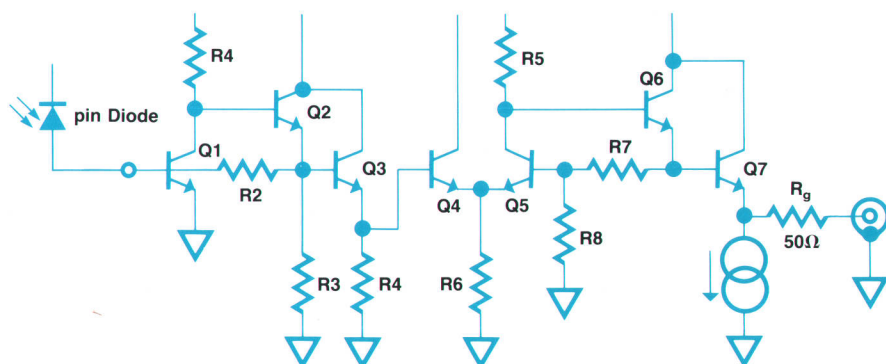

Fig. 4. Schematic diagram of the high-frequency amplifier.

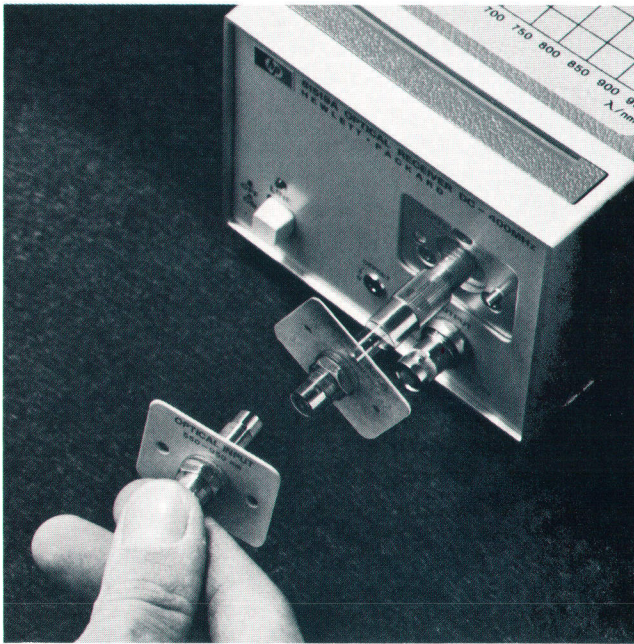

Fig. 5. The optical input connector pulls out for easy cleaning, as shown in this multiple-exposure photograph.

MHz along with 13-dB voltage gain was achieved, which means that unity gain of the amplifier is only about a factor of two below the β -transit frequency of the transistors used.

Cleanable Optical Connector

The optical input connector of the instrument is cleanable. It is imperative that optical connectors be kept clean to maintain performance within the published specifications. A dirty connector can cause attenuations of 1 dB or more.

To make the cleaning procedure for the optical input connector as easy as possible, the connector can be pulled out of the front panel (Fig. 5). In the extended position, it supports itself automatically. The fiber feedthrough can be removed and the fiber end can be cleaned according to the instructions in the cleaning kit that is available as an accessory. It is not necessary to use special tools or open the instrument.

Acknowledgments

We wish to thank the HP 8150A and HP 8151A design teams, who contributed valuable assistance based on their considerable optical experience. Special thanks to Bill Brown of HP Laboratories, who did many useful investigations of the transimpedance stage of the HP 81519A.

Optical Standards

by Werner Berkel and Joachim Vobis

AFTER THE SPECIFICATIONS of the HP 8151A Optical Pulse Power Meter and the HP 8150A Optical Power Source were fixed, we had to find ways to measure the dc accuracy, rise time, and bandwidth of these instruments, since suitable instruments were not commercially available. For this purpose we developed two optical standards that have higher precision than the HP 8150A and HP 8151A.

The first standard is a high-precision dc optical power meter that works at a wavelength of 850 nm. This standard is used to calibrate and test the HP 81511A Optical Head and the HP 8150A Optical Power Source for dc accuracy. It has the quality and accuracy of a secondary standard and is traceable to NBS in the U.S.A., PTB in Germany, and other national standards laboratories. In production and maintenance, it will be recalibrated every six months. A similar standard that works at 1300 nm is used to calibrate the HP 81512A Optical Head.

Main Specifications of the Optical Power Meter Standards

Radiant Power	Measured in Range	Accuracy Relative to Calibration at 10 μ W
2 mW 100 μ W	1V/1 mW	$\pm 1.5\%$ $\pm 1.5\%$
10 μ W 1 μ W 100 nW	1V/10 μ W	$\pm 1.0\%$ $\pm 1.3\%$ $\pm 1.3\%$
10 nW 1 nW	1V/100 nW	$\pm 2.6\%$ $\pm 2.9\%$

In these instruments, a silicon pin diode transforms the optical power to an equivalent current. To achieve a stable

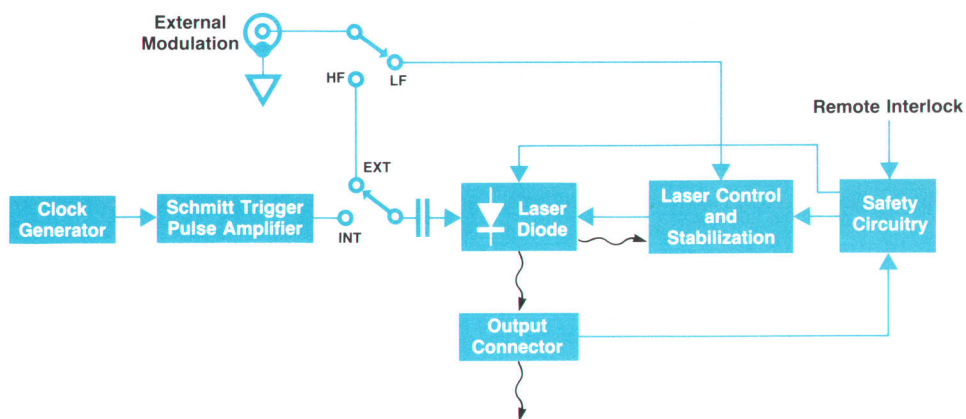

Fig. 1. Block diagram of the optical rise time standard.

conversion factor, the diode is temperature-controlled to within $\pm 0.1^\circ\text{C}$. An operational amplifier transforms the diode current to an output voltage given by

$$V_{\text{out}} = I_{\text{diode}}R$$

Depending on the range, the resistor R is switchable in three steps.

Rise Time Standard

The second optical standard is for rise time measurements. Its main specifications are:

Wavelength	850 nm
CW Power	2 mW
Pulse Performance	
High Power Level	1 mW
Low Power Level	250 μW
Frequency	10 kHz to 10 MHz
Duty Cycle	50%
Rise Time	1 ns (10% to 90%)

This instrument operates as follows (see Fig. 1). Clock circuits generate a square-wave signal, selectable from 1 kHz to 10 MHz, with 50% duty cycle. A Schmitt trigger, together with a 1-GHz-bandwidth amplifier, decreases the electrical rise time to 300 ps. The pulses are added to the

bias current produced by a laser control. A specially selected GaAlAs laser diode converts the electrical signal into an optical signal. A 400- μm step-index fiber leads the back-face laser beam to a pin diode whose current is proportional to the average light power. This current is used to regulate the bias current for constant light power.

The laser's output fiber is furnished with the same output connector used in the HP 8150A. Two complementary switches furnish the connector state (output unconnected, connected to a fiber, or failed) to the safety circuits. If no connector is correctly applied or if the remote interlock loop is not closed, the laser diode is shorted and the laser control is driven to the off state.

This 850-nm instrument is used to produce and service the high-speed path of the HP 8151A Optical Pulse Power Meter with the HP 81511A Optical Head. An equivalent 1300-nm standard was developed to test the HP 8151A with the HP 81512A Optical Head.

Because these standards are safety class 3B products (see box, page 8), much care was taken to ensure compliance with international safety standards. The safety parts are tested by the same procedures as a device that will be sold to a customer.

Acknowledgments

We would like to thank Milan Cedilnik and his standards laboratory and Herbert Hesse for their outstanding contributions and their help in constructing the optical standards.

Authors

January 1985

4 — Fiber Optic Instruments

Achim Eckert

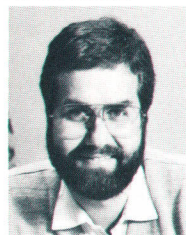

Achim Eckert has been a marketing engineer with HP's Böblingen Instruments Division for nine years. He first joined HP as a regional sales engineer, moving to product marketing in 1979. A year later he took an assignment as local sales engineer in Colorado

Springs to support the logic signal sources product line in the United States over a period of two years. After his return to Böblingen in 1982, he became product marketing engineer for fiber optic test equipment. Once the remodeling of his home is finished, Achim hopes to have more time for his family and his hobbies, which include hiking, reading, and model airplanes.

Wolfgang Schmid

Author's biography appears elsewhere in this section.

7 — Optical Power Source

Bernhard Flade

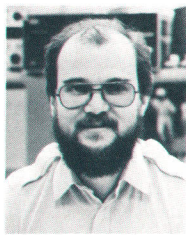

Bernhard Flade served an apprenticeship as an electrician at HP in Böblingen from 1967 to 1970. Later, while studying electrical engineering in Karlsruhe, he did a second apprenticeship as a professional ski instructor. He returned to HP after receiving his

Diplom Ingenieur in 1981. As an R&D engineer at HP's Böblingen Instrument Division, he developed the software for the HP 8150A Optical Signal Source. Bernhard is married and has one son. He's a member of the German and the international associations of ski instructors and a member of a German technical relief organization. He enjoys skiing, motorcycling, and despite his job, working with home computers.

Wolfgang Schmid

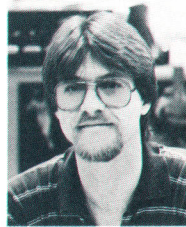

Wolfgang Schmid earned his Diplom Ingenieur at the University of Stuttgart and joined HP as an R&D engineer in 1978. He started working on the newly defined fiber optics products and became project leader of the HP 8150A Optical Signal Source. Wolfgang is

married and has a son. He plays the piano, sings in a classical choir, and enjoys tennis, hiking, and cross-country skiing.

Klaus Hoeing



Klaus Hoeing studied electrical engineering in Stuttgart. He joined HP's Böblingen Instruments Division in 1980 as an R&D engineer. After working on several problems of the ICs for the HP 8111A/8112A/8116A Pulse/Function

Generators he joined the fiber optic team and was responsible for the final design of the HP 8150A hardware. He is single and enjoys woodworking and sailing.

Rainer Eggert



Rainer Eggert joined HP nineteen years ago to work in tool design, but he later switched to product design, contributing to the mechanical design of several products. Before joining HP, he had been an apprentice at a lighting equipment firm before attending

the Staatliche Ingenieurschule Gauss in Berlin where he qualified as a Feinwerktechnik Ingenieur Graduate (mechanical engineer). Married and the father of two children, Rainer is interested in cinematography, skiing, and bicycling.

18 — Optical Power Meter

Hans Huning



Born and raised in Münster in Westfalen, Hans Huning studied at the Rheinisch Westfälisch Technische Hochschule at Aachen. After receiving his engineering diploma, he joined HP in 1982 and contributed to the hardware design of the HP 8151A

Optical Pulse Power Meter. Subsequently he was responsible for one of the optical production standards, an optical source for 1300 nm wavelength. Hans is married and dedicates most of his spare time to his two-year-old son and four-month-old daughter. Sky sailing is another of his major pastimes.

Volker Eberle



Volker Eberle earned his Diplom Ingenieur at the Technische Universität Stuttgart in 1975. He then joined HP and contributed to the design of the HP 8092A Delay Generator. He was project leader for the HP 8080A Configurable

1-GHz Pulse Generator, for the Booster IC which is used in several instruments, and finally for the HP 81511A Optical Head. Volker is married and has two daughters. His leisure activities are gardening, model railroading, and playing the accordion.

Josef Becker

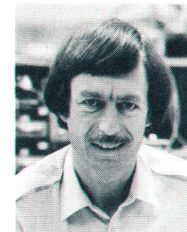

Jo Becker joined HP towards the end of 1979, having previously worked at the University of Stuttgart as a biomedical engineer. He was responsible for the design of the HP 8180A Data Generator output amplifiers, and has now moved to the fiber optics

group at HP's Böblingen Instruments Division, where he is involved in the development of detector heads. Jo is married and has three sons. His hobbies include amateur radio and astronomy.

Michael Goder

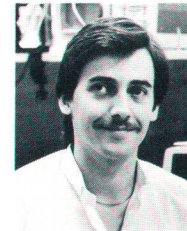

Michael Goder is a native of Wesel am Rhine. In 1979 he received his Diplom Elektroingenieur at the Engineering School in Duisburg. He joined HP in the same year as an R&D engineer, working on fiber optics. He developed the software for the HP 8151A and

is now working on other fiber optic products. Michael is interested in photography and motorcycles and enjoys downhill skiing. He is married and lives in Böblingen.

Bernd Maisenbacher

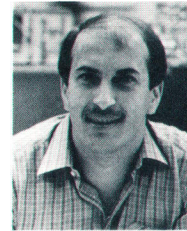

A native of the Black Forest area, Bernd Maisenbacher joined HP in 1981 after receiving the equivalent of an MSEE degree from the University of Stuttgart. He was responsible for digital hardware and software development for pulse and data generators, and then

served as project leader for HP 8150A/51A software development. He's now working on a new fiber optic development project. Bernd enjoys tennis, skiing, dancing, and collecting stamps.

Wilfried Pless



Wilfried Pless received his Diplom Ingenieur in 1982 from the Ruhr Universität Bochum. He joined HP in 1983 and his main task has been to develop software for the HP 8151A. Wilfried is a native of the Münsterland and now lives in Böblingen. His spare time is filled with family activities—he's married and has two children.

Werner Berkel

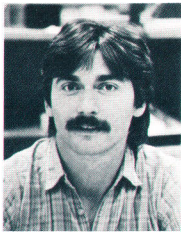

Werner Berkel was born in Speyer, Federal Republic of Germany. He joined HP's Böblingen Instruments Division in 1978, contributed to the design of the HP 8180A Data Generator, and supervised the design of the HP 15413A Tri-State Unit and the HP 81514A Tri-State Pod. He then moved to the fiber optic group and became project manager for the HP 8151A/81511A Optical Pulse Power Meter. Werner is married and enjoys music, soccer, and table tennis.

27 — Optical Receiver

Emmerich Müller

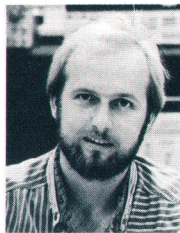

Emmerich Müller earned his Diplom Ingenieur (FH) at the Engineering School in Furtwangen (Black Forest). He joined HP shortly thereafter as a development engineer and contributed to the design of a variety of products. He was responsible for the mechanical and optical development of the HP 81519A. Emmerich is married, has a son, and enjoys cycling and all kinds of skiing.

Michael Fleischer-Reumann

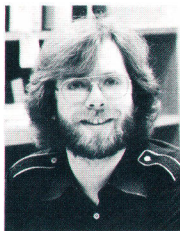

A native of Essen, Michael Fleischer-Reumann joined HP in 1980 after receiving his engineering diploma from the Ruhr University of Bochum. After contributing to the hardware design of the HP 8112A 50-MHz Pulse Generator he worked on custom IC design and finally became project leader for the HP 81519A Optical Receiver. Michael lectures in electronics at a Stuttgart college. He is married, is interested in photography, and likes to spend his spare time traveling in his camper van, backpacking, white-water canoeing, or playing his guitar.

Gerd Koffmane

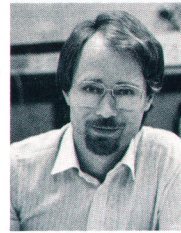

Gerd Koffmane earned his Diplom Ingenieur at the University of Stuttgart in 1983. He then joined HP's Böblingen Instrument Division as an R&D engineer and has contributed to the design of the HP 81519A Optical Receiver. Gerd is married and likes sailing, bicycling, and playing his guitar.

29 — Optical Standards

Joachim Vobis



A native of Heidelberg, Joachim Vobis received his Diplom Ingenieur from the University of Karlsruhe. Joining HP in 1983, he designed the laser optical standard for the HP 8151A and is now working on fast analog circuits for fiber optic measuring instruments. He is married, has a son and two daughters, and enjoys swimming. He also teaches courses on the Pascal computer language.

Werner Berkel

Author's biography appears elsewhere in this section.

Hewlett-Packard Company, 3000 Hanover Street, Palo Alto, California 94304

HEWLETT-PACKARD JOURNAL

January 1985 Volume 36 • Number 1

Technical Information from the Laboratories of Hewlett-Packard Company

Hewlett-Packard Company, 3000 Hanover Street
Palo Alto, California 94304 U.S.A.

Hewlett-Packard Central Mailing Department
Van Heuven Goedhartlaan 121

1181 KK Amstelveen, The Netherlands

Yokogawa-Hewlett-Packard Ltd., Suginami-Ku Tokyo 168 Japan
Hewlett-Packard (Canada) Ltd.

6877 Goreway Drive, Mississauga, Ontario L4V 1M8 Canada

Bulk Rate
U.S. Postage
Paid
Hewlett-Packard
Company

CHANGE OF ADDRESS: To subscribe, change your address, or delete your name from our mailing list, send your request to Hewlett-Packard Journal, 3000 Hanover Street, Palo Alto, CA 94304 U.S.A. Include your old address label, if any. Allow 60 days.